

# Orbital 3300 Series

## C-BAND PLL BLOCK DOWN CONVERTER



10 to 40 dB gain, 250 to 800 MHz bandwidth

### How to order a 3300 Series C-Band PLL BDC

Frequencies (GHz):

LO	Input	Output	Bandwidth
5.15S	- 3.70 to 4.20	.95 to 1.45	0.500
5.15S	- 3.60 to 4.20	.95 to 1.55	0.600
5.15S	- 3.40 to 4.20	.95 to 1.75	0.800

Bandwidth in MHz

'P' Signifies PLL - Phase Lock Loop

BDC 515S - 800 P-SF 20 -G

Input Connector  
S - SMA, 50 ohm

Output Connector  
F - F, 75 ohm  
N - N, 50 ohm  
S - SMA, 50 ohm  
T - TNC, 50 ohm

Gain  
20 - 20 dB

Optional  
G - Temperature Compensated Gain

### Orbital Flexibility:

With an LNA that covers your satellite, simply order a custom Orbital BDC to cover the bandwidth that you need. You can specify input and output connector types, external DC input, coaxial DC input, or dual power option. Most importantly, we can customize your gain to optimize compression point and noise distribution. Just tell us your needs and we will build a mass-custom solution in a unique, cost effective way.

### "Mass-Custom" Solution

Orbital starts with a proven performance product that is extremely well engineered with the development costs amortized over hundreds of thousands of units and the parts costs reduced by volume discounts. We then customize the mass produced LNB into what you want at 1/100 the cost of designing and building from scratch.

### Orbital Features:

#### **Custom Engineering**

- Begin with the low noise figure of a proven quality LNB
- Optimize Input and Output for superior VSWR
- Modify LO frequencies preserving phase noise and stability
- Modify and tune RF & IF filters for optimum response
- Tune for very low bandpass ripple
- Optimize Gain distribution for your system parameters

#### **Environmental**

- O ring sealed connectors for weather resistant operation
- RoHS & REACH compliant

#### **Options**

- External DC connector - F, N, BNC or Feedthrough
- Special Dual DC option via output coax and ext DC port
- Temperature Compensated Gain Variation
- Full test documentation available

**Sales contact:**

[sales@orbitalresearch.net](mailto:sales@orbitalresearch.net)

1 604 419-8585

[www.orbitalresearch.net](http://www.orbitalresearch.net)

# Orbital 3300 Series C Band PLL BDC Specifications

## Mechanical Drawing

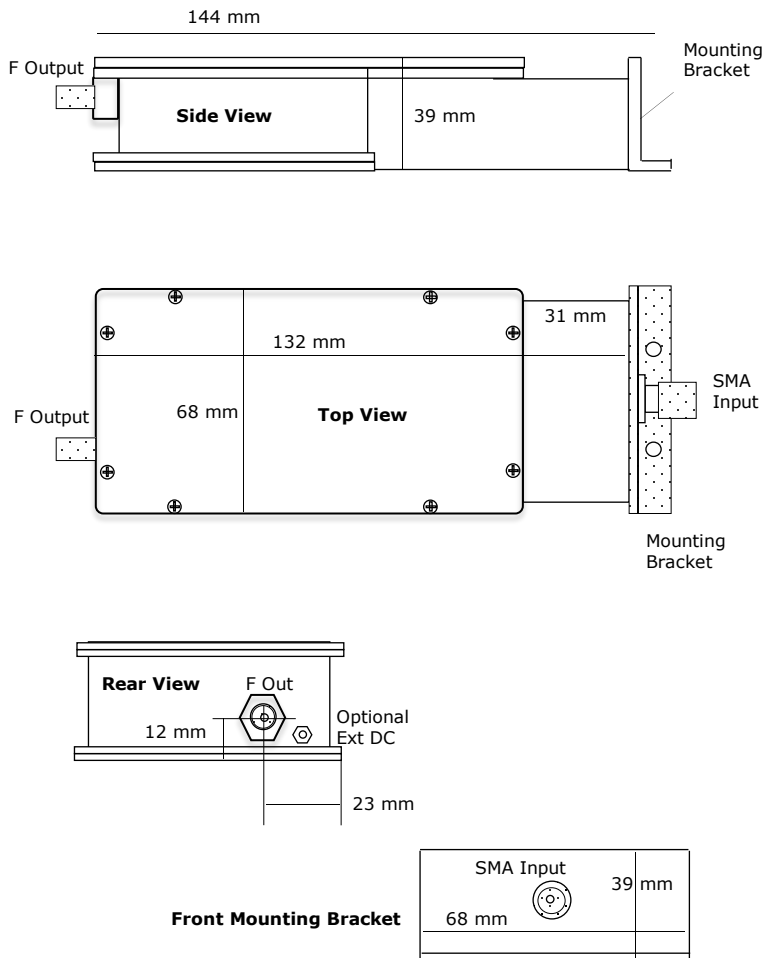

## Electrical Specifications

### Input

Frequency: 3.4-4.2, 3.6-4.2, 3.7-4.2 GHz.  
Other ranges available  
Bandwidth: up to 800 MHz  
Noise Figure: 10 dB max  
Input VSWR: 1.5 : 1 typical  
LO Leakage: -45 dBm max

### Output

Bandpass: 950 up to 1750 MHz  
Output VSWR: 1.5 : 1 typical  
LO Stability:  $\pm 5$  kHz  
1 dB Comp pt: +10 dBm minimum  
3rd Order Intercept: +20 dBm minimum  
LO Leakage: -45 dBm max  
Image Reject: 45 dBm  
Phase Noise: -80 dBc/Hz @ 1 kHz  
-85 dBc/Hz @ 10 kHz  
-95 dBc/Hz @ 100 kHz

### Gain

Options: 20 dB  
Ripple: 1dB p-p max per 36 MHz segment  
Temperature Compensated Gain Variation (optional)  
 $\pm 0.75$  dB max over frequency band and -10 to +55 °C temp range

### Power

DC Input: 12 to 24 VDC, 250 mA typical  
Filtering: Transient, over and reverse voltage protected

## Mechanical Specifications

Size: 144 x 68 x 39 mm  
5.7 x 2.7 x 1.5 inches  
Weight: approx. 550 grams, 19.4 ounces  
Paint: Brilliant White Enamel  
RoHs & REACH Compliant

## Environmental Specifications

Operating Temp: -40 to +60°Celsius  
Relative Humidity: to 100% condensation & frost

## Block Diagram

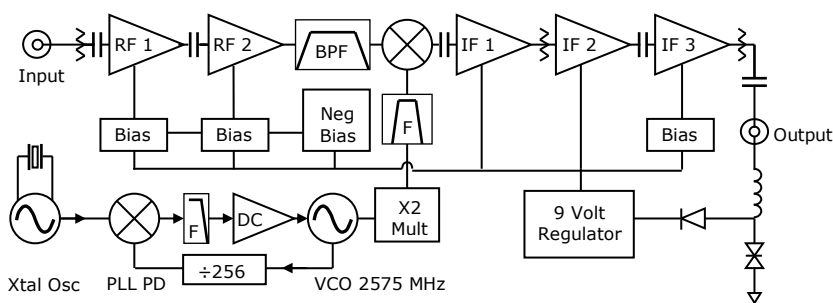

## Enhancing Standard Product

Mass-production means low-cost, reliable, repeatable products. Engineers design these products well within margins on component specifications so that individual tuning is not required to meet desired specifications.

As we modify product, we also tweak the design and components to optimize them for their inherent capabilities. Effectively, we bring out the full potential of the product by adjusting components to their full capability.

Orbital Research Ltd. designs and builds products for satellite communications applications. Orbital sells directly and from its website [www.orbitalresearch.net](http://www.orbitalresearch.net). Copyright © 2017 Genie in the Bottle Enterprises Inc. All rights reserved. Specifications subject to change without notice.