

Redundant C Band 1:2 LNB System - ODU

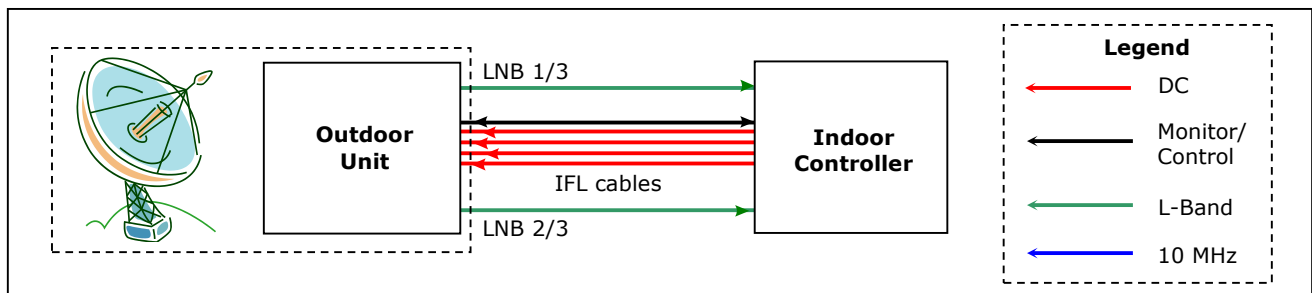
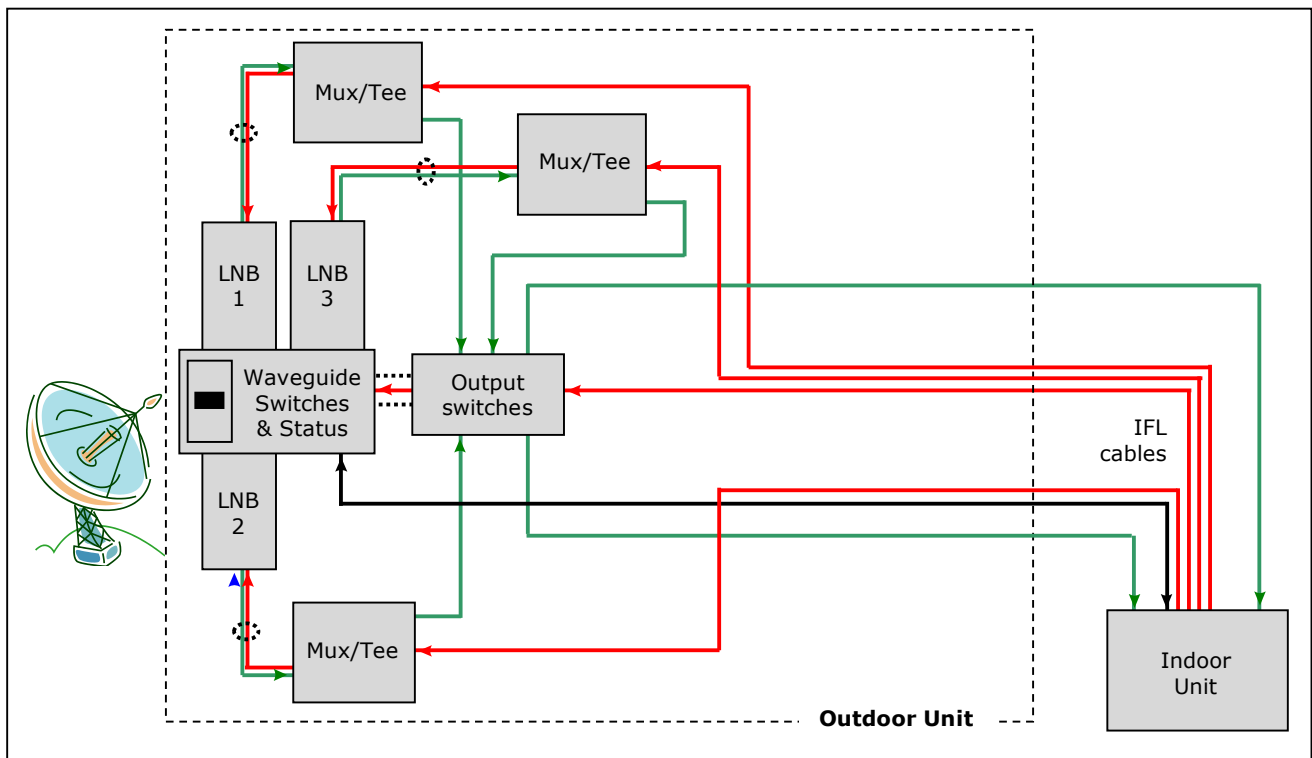

Orbital ODU Features:

- Industry standard IFL with two coax cables and one control cable.
- Uses standard LNBs from any manufacturer. LNBs are included and tested in the system
- The Outdoor Unit is compact on one rail which is rack-mountable on a 19" rack
- ODU is pre-assembled on a 2 RU 19" plate and fully wired and tested for plug and play installation.
- The IDU is a 1RU chassis. Just connect the cables, plug the redundant power supply in and you are ready to go.

Redundant C-Band 1:2 LNB System - IDU

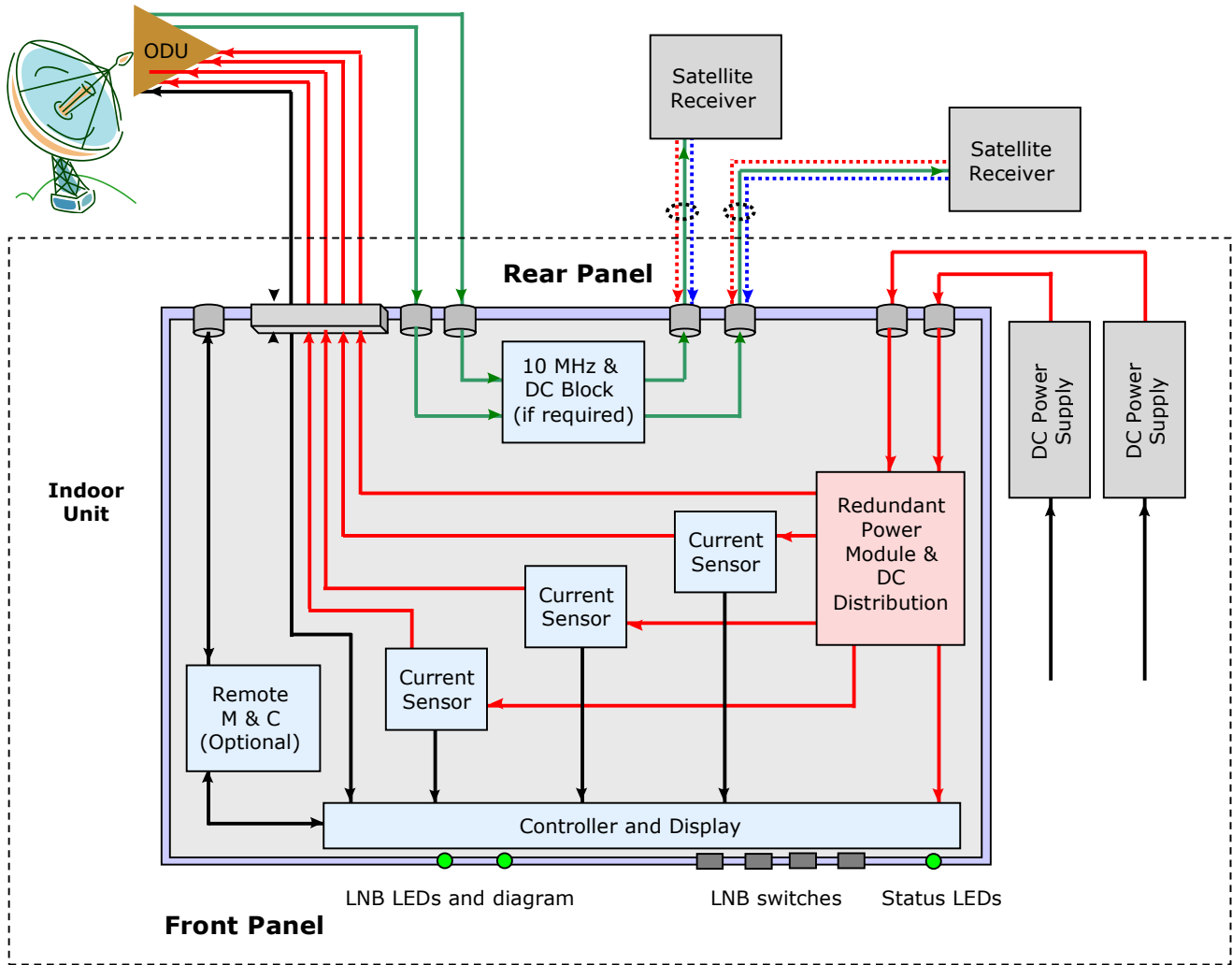

Orbital IDU Features:

- The coax cables can go directly to the modems if the DC and 10 MHz can be shut off. Or the indoor controller can have DC & 10 MHz blocks in place if the modems can't shut them off.
- 1 unit high chassis. Simple LED display for monitoring. No cumbersome LCD menu to work through
- Redundant Power Supply that is outside of chassis for easy service and replacement. Global power supplies to use anywhere in the world
- Manual or automatic switching between LNBs.

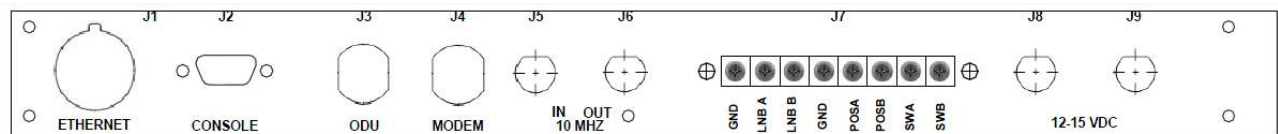
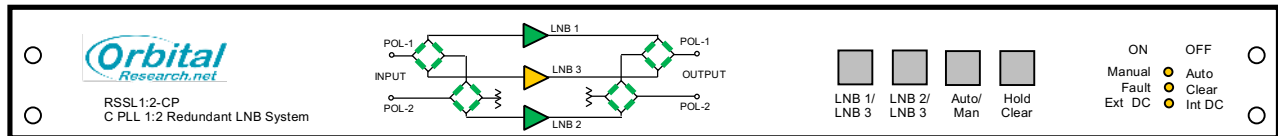

RSSL1:2-CP: C Redundant LNB system - Specifications

ELECTRICAL

INPUT (Outdoor unit)

Interface: CPR-229
Frequency: 3.4 to 4.2 GHz
4.5 to 4.8 GHz
Non-standard frequencies available as well.
Noise Figure: 0.7 dB typical @ 23°C
0.8 dB typical with input waveguide isolator
VSWR: 2.5 : 1 typical

OUTPUT (Outdoor unit)

Connector: F, N or SMA
VSWR: 1.5 : 1 typical
Gain: 60 dB typical
LO Stability: +/-10 kHz
1 dB Compression: +10 dBm min. for standard LNBs
3rd Order Intercept: +20 dBm min. for standard LNBs

POWER (Indoor controller)

Voltage: 90 - 264 VAC
Frequency: 47 - 63 Hz
External PS conn.: BNC
Filtering: Transient, over and reverse voltage protected

*More detailed specs available on Orbital 3300 LNB brochure.

General Description:

The Orbital LNB redundant switch features a slim, streamline outdoor unit mounted on a 19" rail for easy installation. Mounted LNBs allow easy swap out using industry standard LNBs. The IFL is industry standard with two coax cables for the L-Band signal, and one control cable which carries the DC, 10 MHz and monitor/control signals.

The indoor unit is 1RU-19" with a simple LED display to quickly observe the LNB status, and control buttons to make any required changes to the system quickly and efficiently. LNB redundancy is automatic (current sensing) or manually selected. Power supply redundancy is automatic. Remote M&C is optional.

Orbital Design:

As always, Orbital products are simple, market focused designs of an open architecture type to allow for custom requirements. The redundant switch uses Orbital modules to allow for custom features required by the customer. The indoor controller's front panel is a universal design that allows for customer feature changes.

MONITOR AND CONTROL

Push Buttons	LEDs
LNB 1 / LNB 3	LNB 1, LNB 2, LNB 3
LNB 2 / LNB 3	Automatic / Manual
Automatic/Manual	Fault / Clear
Alarm reset	Ext DC1 / Ext DC2

External Power supplies:

Power supplies, historically, have the lowest MTBF of the components in a system. The Orbital External power supply configuration was designed to provide inexpensive and rapid power supply replacement. A secondary benefit is the lower operating temperature of the external power supplies thus extending their lives.

The external power supplies need to be 18VDC, with a minimum current rating of 1.2 Amps. It is the main power supply. If it fails, the system switches to the other external power supply. This gives the customer time to replace the defective power supply without any down time or without having to take the entire rack mounted chassis in for repair.

MECHANICAL

	Outdoor Unit	Indoor Unit
Weight:	TBD	TBD
Overall Dimensions:	TBD	19" x 1.75" x 20" max
Input Connector:	CPR-229	F, N or SMA
Output Connector:	F, N or SMA	F, N or SMA

ENVIRONMENTAL

	Outdoor Unit	Indoor Unit
Operating Temp:	-40 to +60°C	0 to +55°C
Relative Humidity:	<100%	<95% non-condensing

White Rock, BC
Canada

www.orbitalresearch.net

David Zuvic
1-604-856-0305
dzuvic@orbitalresearch.net

Orbital Research Ltd. designs and builds products for satellite communications applications. Orbital website: www.orbitalresearch.net. Copyright © 2017 Genie in the Bottle Enterprises Inc. All rights reserved. Specifications subject to change without notice.

