

# Orbital X-MIC

## X-Band Ext Ref LNB with internal Isolator



Designed for the expanding Commercial X-Band markets

### How to order an Orbital X-MIC, X-Band External Reference LNB

#### Frequencies (GHz):

LO	Input	Output	Bandwidth
6.30S	7.25 to 7.75	.95 to 1.45	0.500
6.95S	7.90 to 8.50	.95 to 1.55	0.600

Other frequencies available upon request

Bandwidth in MHz

'X' Signifies External Reference

**LNB630S-500X-IWN60**

#### Integrated Input Isolator

I - MIC isolator

#### Input Connector

X LNB is WR-112

#### Output Connector

F - F, 75 ohm  
N - N, 50 ohm  
S - SMA, 50 ohm  
T - TNC, 50 ohm

#### Gain

60 - 60 dB

### Orbital Features:

The new X-MIC LNB is the evolution of our high performance X-Band LNB. Orbital has brought the isolator inside to effectively reduce the overall size and weight. Over the sale of thousands of X-Band LNBs, we have learned that the isolator is necessary in ALL applications. Bringing it inside makes the entire LNB hermetically sealed with a more standard overall size.

This change does not negatively effect any of the performance specs.

### Improvements:

- Integrated Isolator which provides less weight and smaller (more standard) package
- Increased Transmit Reject filtering: 55 dB
- Switching power supply which provides:
  - Increased input Voltage range: 12 to 28 VDC
  - Lower power consumption: 3.8 Watts max

The X-MIC was designed for LEO, MEO, drones, FEMA, emergency services and Earth Observation Satellites along with the standard military VSAT use.

### Orbital Specs:

- P1 dB >15 dBm (typical)
- IP3 >25 dBm (typical)
- Noise Figure 0.7 ~ 0.8 dB (typical)
- CE, RoHS & REACH compliant

### Sales contact:

**David Zuvic**  
Tel: 1-604-856-0305,  
dzuvic@orbitalresearch.net  
[www.orbitalresearch.net](http://www.orbitalresearch.net)

# Specifications



## **Frequency Range:**

Input RF Frequency: Various from 7.25 - 8.5 GHz  
Output IF Frequency: 950 to 1750 MHz  
Local Frequency: Dependent on input range  
LO Stability: Phase locked to external 10MHz reference

## **Gain:**

Gain: 60 dB  $\pm$ 2 dB over temp & freq  
Ripple:  $\pm$ 0.5 dB over any 10 MHz segment  
Flatness:  $\pm$ 2dB max over freq  
Stability:  $\pm$ 1dB max over 24hr @ +25°C

## **VSWR:**

Input: 1.3:1 max (integrated input isolator)  
Output: 2.0:1 max

## **Amplitude Response:**

10 MHz Band:  $\pm$ 0.3dB max  
120 MHz Band:  $\pm$ 1.0dB max  
Receive Band:  $\pm$ 1.5dB max

## **Noise Figure:**

0.7-0.8 dB typ. @ +23°C

## **Interfaces:**

Input: CPR-112 flange modified 12-hole Waterproof (when mated with matching flange and gasket)  
Output: N, 50 $\Omega$  female, coax connector.  
Optional: SMA (50 $\Omega$ )

## **Environmental:**

Operating Temp: -40°C to +60°C  
Operating Altitude: 10,000 ft ASL  
Operating Rel Humidity: 100% condensing  
Non-operating Temp: -50°C to +70°C  
F Shock: 20g, 11ms, half sine  
Vibration: MIL-STD-810F, method 514-4  
MTBF: >125,000 hours  
Optional Military Mobile Vibration Spec:  
Mil-Spec 810F chapter 514.5C-1,  
& temp range of -30 to +70°C  
Compliances: RoHS & REACH

## **10 MHz Reference:**

Insertion: Multiplexed onto the IF coaxial connector  
Input Level: -5 to +5 dBm  
Phase Noise: -135dBc/Hz max. @ 100Hz  
-148dBc/Hz max. @ 1kHz  
-152dBc/Hz max. @ 10kHz  
-155 dBc/Hz max. @ 100kHz

## **Mechanical:**

Dimensions: 70 x 55 x 146 mm  
Color: White (standard)  
Weight: 750 grams

## **LNB 10 MHz Phase Noise:**

-62dBc/Hz max. @ 100 Hz  
-72dBc/Hz max. @ 1 kHz  
-82dBc/Hz max. @ 10 kHz  
-92dBc/Hz max. @ 100 kHz  
-102dBc/Hz max. @ 1 MHz

## **Power:**

DC in: +12 to +28 VDC  
Power: 3.8 Watts max  
Interface: DC power is multiplexed with the IF & 10 MHz reference signals on the output connector

## **Other Specs:**

LO Leakage: Output: -35 dBm max  
Input: -45 dBm max at waveguide flange  
Filter: 55 dB Attenuation (Transmit Reject)  
Image Rejection: -40 dBc max  
P1 dB comp pt: +15 dBm (typical)  
OIP3: +25 dBm (typical)  
Desense level: @ -40dBm, <0.1dB  
Overdrive: -20 dBm, non-damaging  
In band spurs: -45 dBc max

# Mechanical drawing

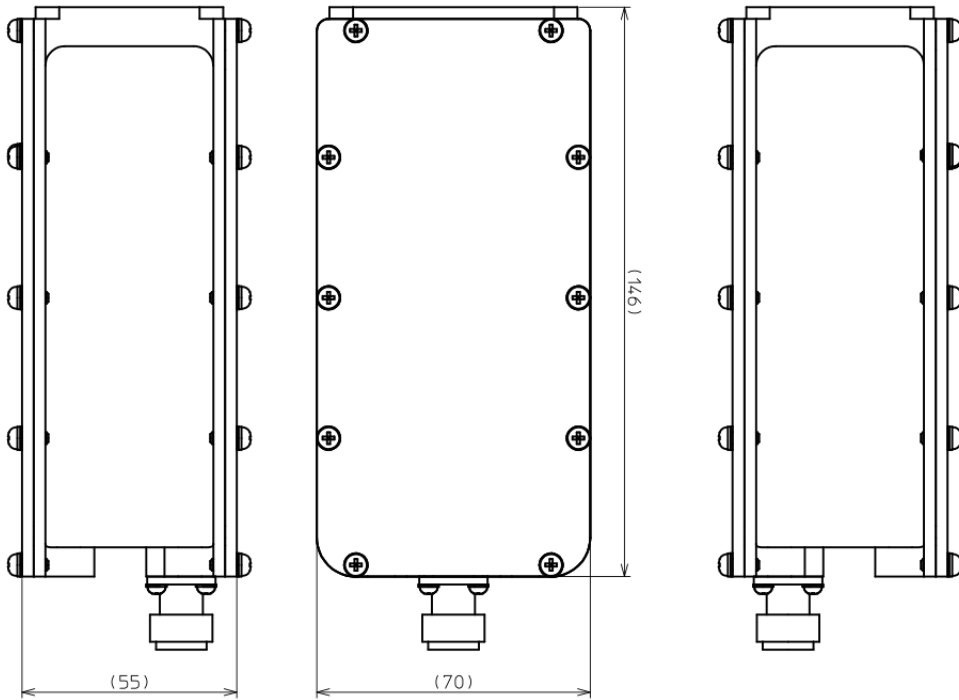
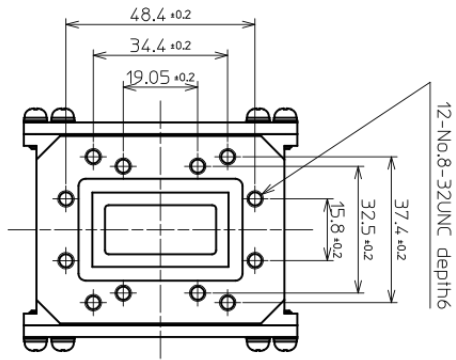

X-LNB with built-in isolator outline drawing

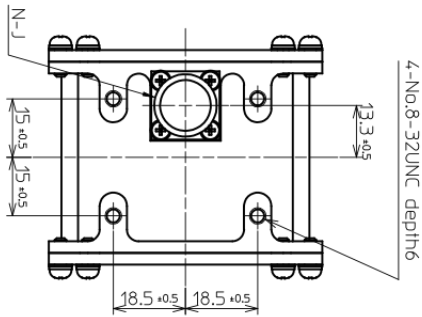

UNIT mm

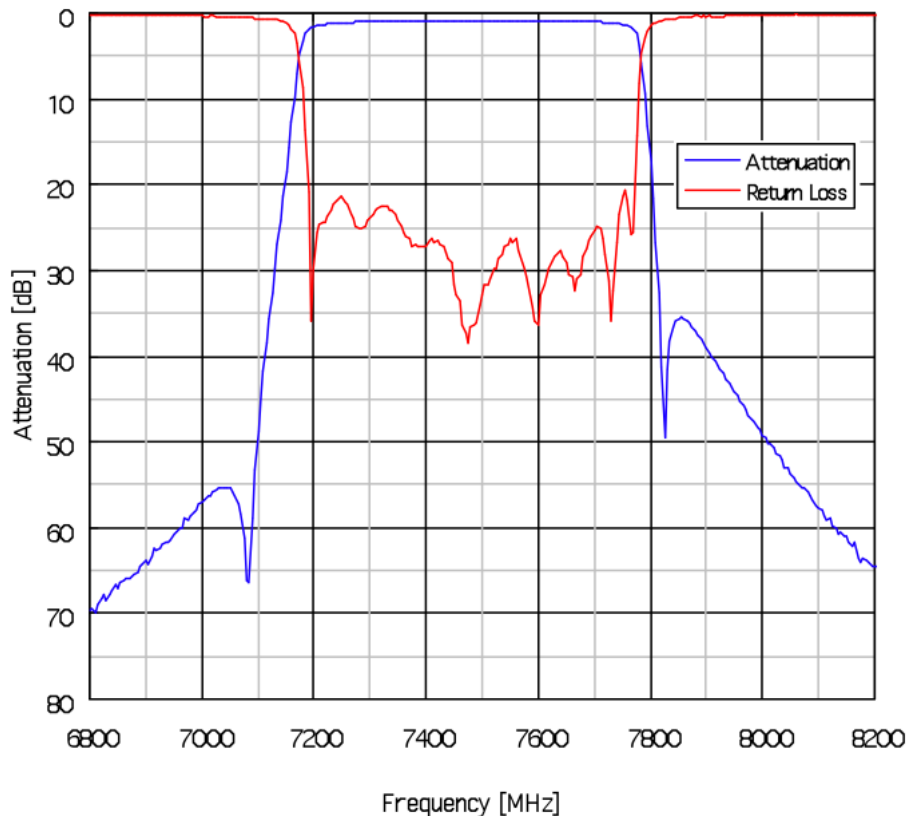

Internal Filter Frequency Response

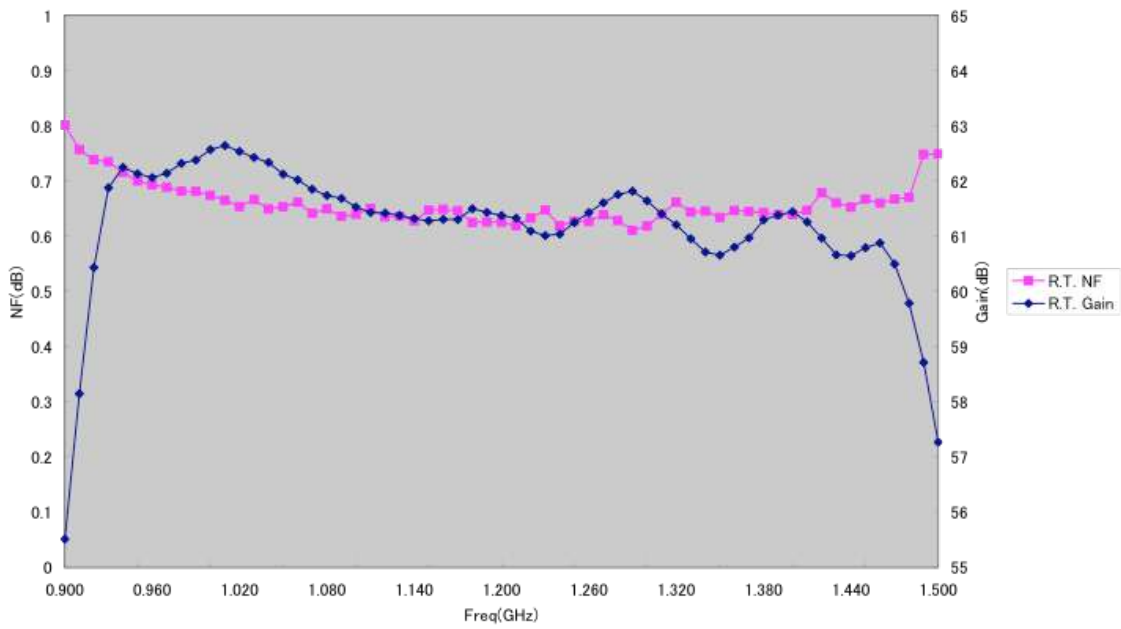

Noise Figure and Gain

## Two Tone Test

**What it means** - The two plots below compare gain linearity for the Orbital design with competitor designs. Two tones at 7.500 GHz and 7.501 GHz are injected into the LNBS to provide 0 dBm out. The first spur in the Orbital design is over -60 dBc down compared to the multiple spurs on the competitive LNB starting at only -20 dB down. Intermodulation (IM) distortion for a given output is reduced in the Orbital LNB while providing higher overall gain, 60 dB minimum for the Orbital LNB.

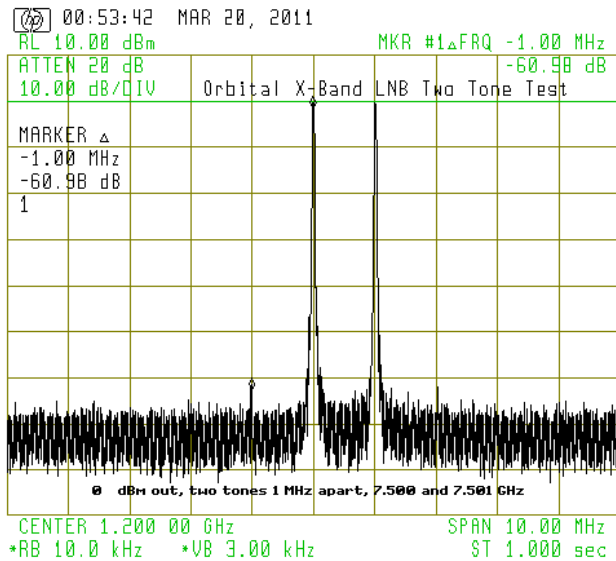

Orbital LNB

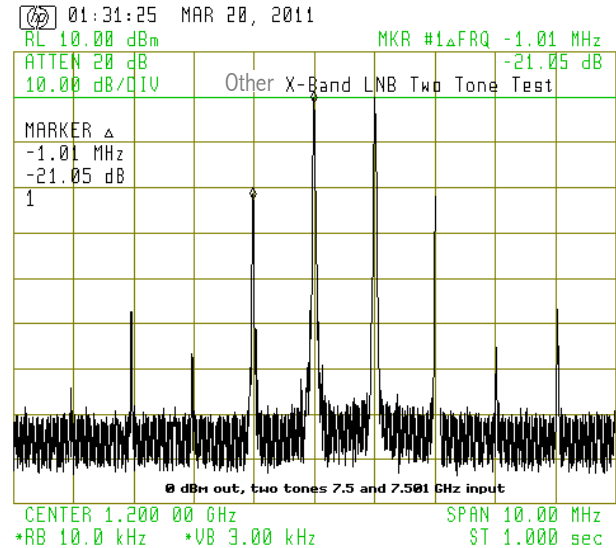

Competitor LNB

**How it works** - The LNB has to amplify the multiple signals from the satellite by a factor of a million (60 dB) without adding significant noise (noise figure), but also to perform this conversion without adding distortion. The above graphs represent the comparative levels of distortion between the Orbital design and competitive designs. Basically, if you put two signals into the LNB, you should get two signals, and only two signals, out. You can imagine the mess using a poor quality LNB when you amplify and convert the dozens or even hundreds of signals from the satellite.

**What it shows** - While an LNB would never be operated at 0 dBm output level, the test and design represent the linear conversion quality of each LNB and the P1 dB compression point. The Two Tone tests are proxies for the quality of conversion that is absolutely necessary for low bit error rate satellite transmissions. LNB non-linearity starts at much lower levels than 0 dBm output, and the 2 tone test is the best method of comparing the quality of design and manufacture of LNBS. The ultimate benefit to the end user is lower noise figure, higher conversion gain, and most importantly, lower bit error rate for their digital transmissions.

Orbital Research Ltd. designs and builds products for satellite communications applications.  
Orbital website: [www.orbitalresearch.net](http://www.orbitalresearch.net). Copyright © 2017 Genie in the Bottle Enterprises Inc. All rights reserved. Specifications subject to change without notice.

