



R10DA: 2 input, 4 output

System Interface Product

Redundant 10 MHz Switch & Distribution Amplifier



R10DA Description

Orbital Research's R10DA is a 10 MHz Reference signal distribution splitter and variable gain amplifier that will automatically (or manually) select one of two inputs.

On board RF detectors allow the system to automatically detect the level of incoming signals and set the output to the appropriate level, even if the input signals are of different levels.

Orbital's R10DA is designed as a carrier grade module for systems that demand high availability and high performance whether it is for a head-end or remote VSAT.

Mechanical Specifications

Size (case): 87l x 130w x 45h mm
 Weight: 32 oz
 Paint / Color: Blue Anodized finish
 Mounting holes: 3/8" (5mm)
 Accepts standard rackmounting screws: 10/32 or 10/34

Environmental Specifications

Operating Temp: -40 to +50° Celsius
 Relative Humidity: UP to 100% condensation and frost

R10DA Features

- Port to Port Output Isolation >20 dB
- Switched input Isolation >50 dB
- Insertion Loss <0.5 dB
- VSWR < 1.50:1 (all ports)
- Phase Balance <5 deg
- P1 dB (with 0dB attenuation):
 - Input > 6.0 dBm
 - Output > 11.0 dBm
- Gain Range: +10 to -10 dB (in 0.5 dB steps)
- Fixed gain (set to a desired gain)
- AGC – Automatic Gain Control (maintain desired output level regardless of input),
- Amplitude Imbalance: <0.2 dB
- Power: 5 to 40 VDC (<150 mA)
- IP67 rated connectors ("O" ring sealed) & hardware

Connections

- RF Connectors: SMA standard, BNC, TNC, N Optional
- M&C Connector: M8 IP67 rated multi-pin or Mini USB
- DC Connector: M8 IP67, BNC or Solder Lug
- USB Connector: IP67 rated mini USB B

Functional

- Can be used with LNBS, BDCs, BUCs, VSATs, etc.
- Optional local control and status indicators
- Optional remote monitoring: Form C, USB, RS485

Structural

- Machined from a solid aluminum billet for strength and stability
- Anodized finish for corrosion protection and excellent RF shielding/grounding

Contact

Trevor Hiebert 604-419-8585 ext. 836 thiebert@orbitalresearch.net

David Zuvic 604 419-8585 ext. 837 dzuvic@orbitalresearch.net

Part Number Generator

Module – R10DA
Redundant 10 MHz
Distribution Amplifier

J-5 to J-8
Output
Connectors

J-4
DC
Connector

Connectors available:

J1, J2, J5-J8: 10 MHz

S - SMA, 50Ω

B - BNC, 75Ω

N - N, 50Ω

J3: M&C

mU- Mini USB

J4: DC Supply

B - BNC (preferred)

N - N

S - SMA

T - TNC

Ft - feedthru

R10DA – S S – S S S S – mU B

J-1, J-2
Input
Connectors

J-3
M&C
Connector

BNC-to-pigtail adapters and BNC-to-binding post adapters sold separately.



Mechanical & Block Diagram

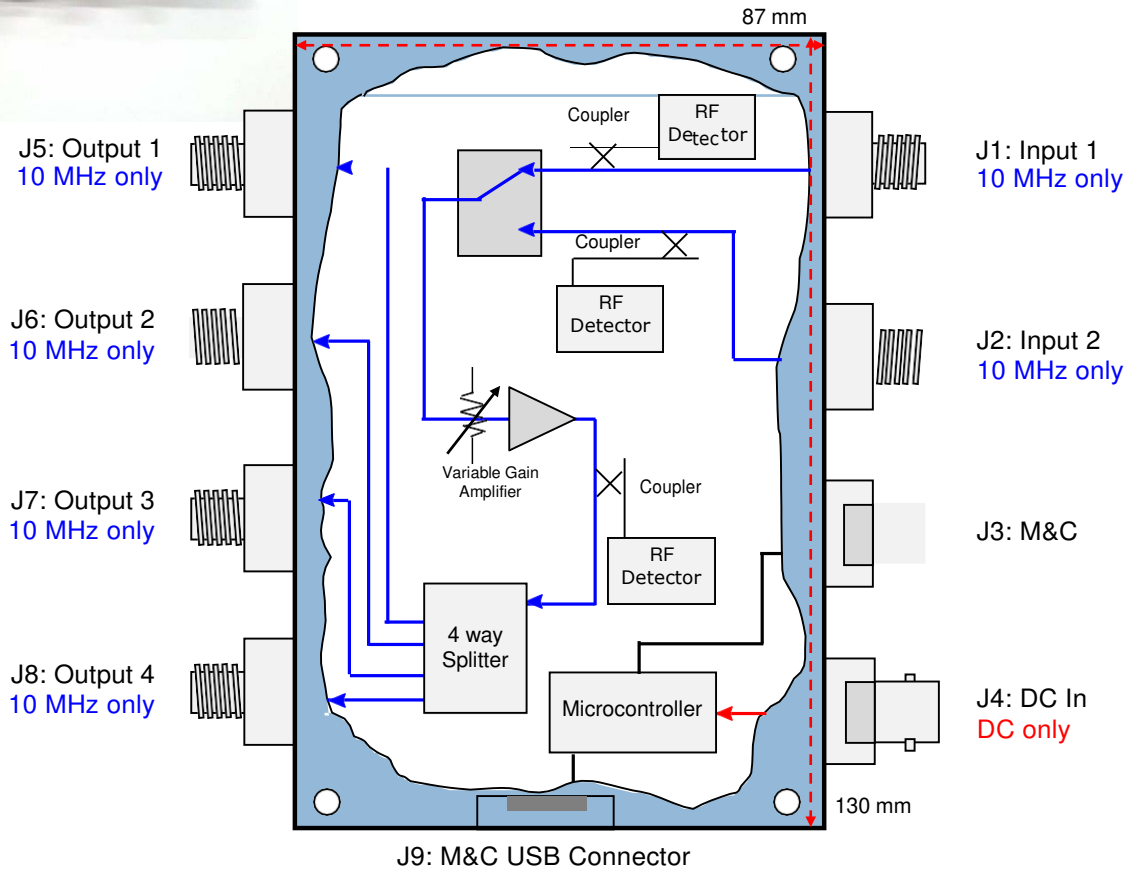

Application Examples

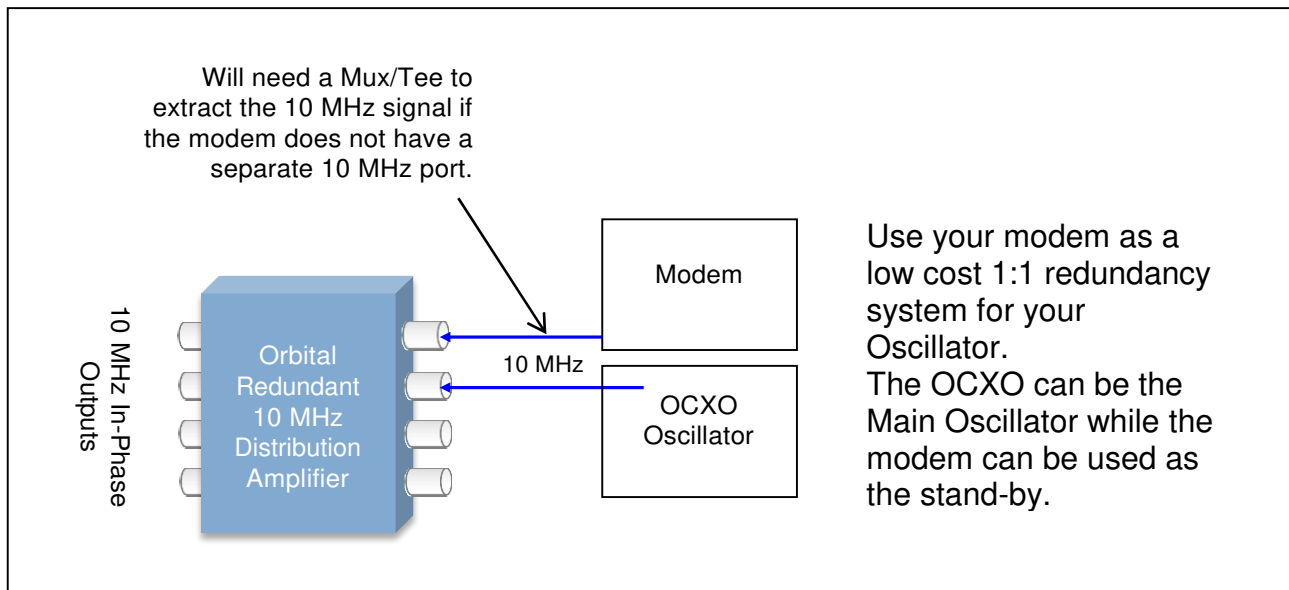
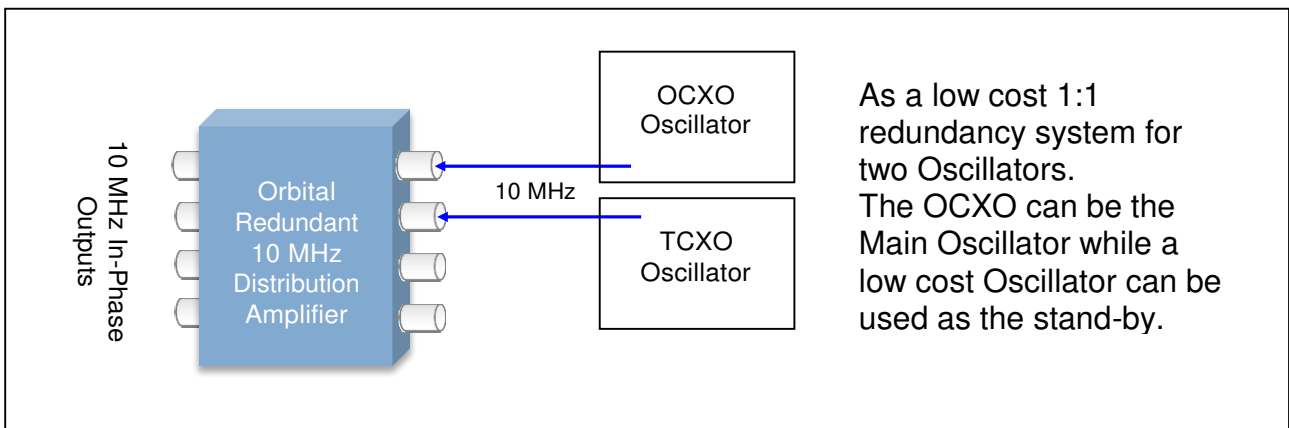
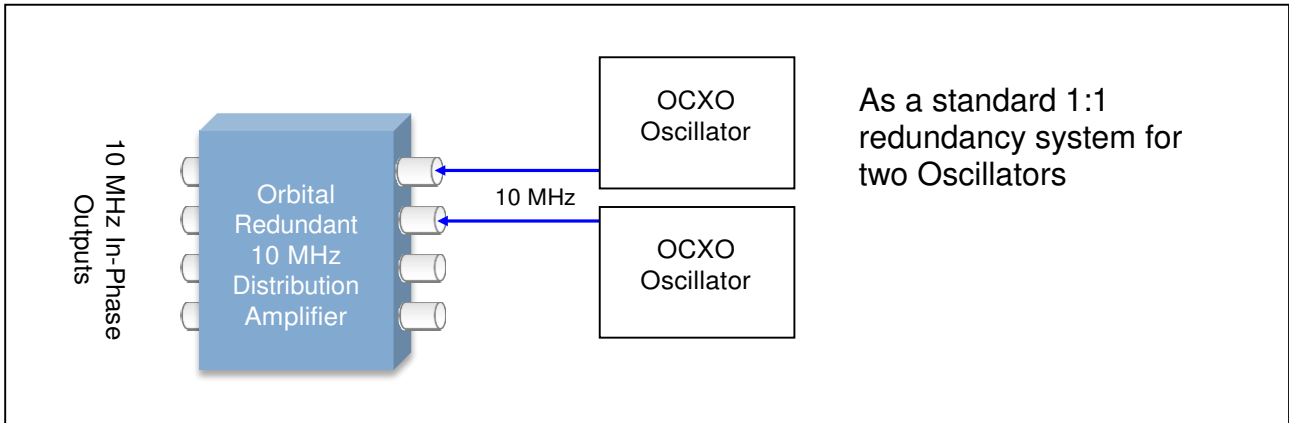

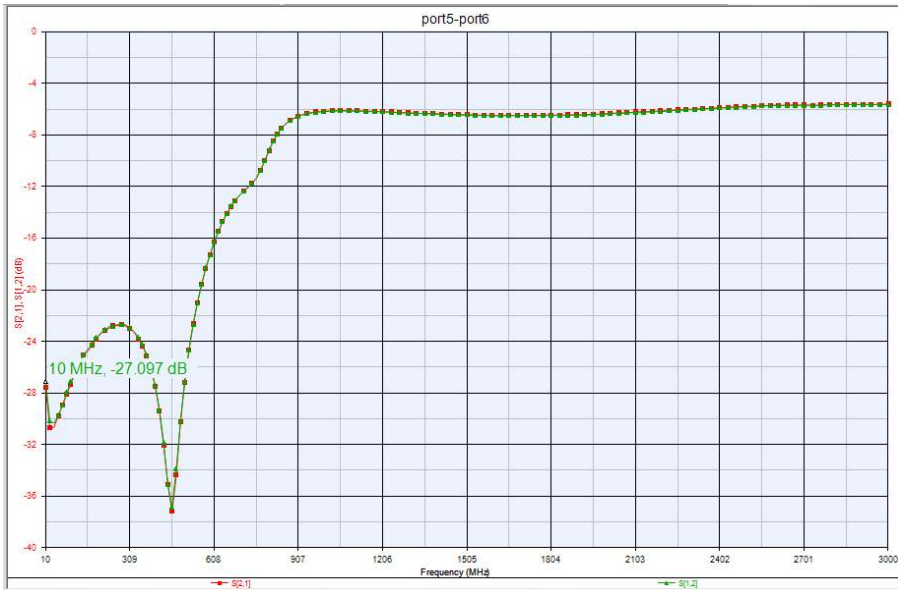

Port to Port Isolation

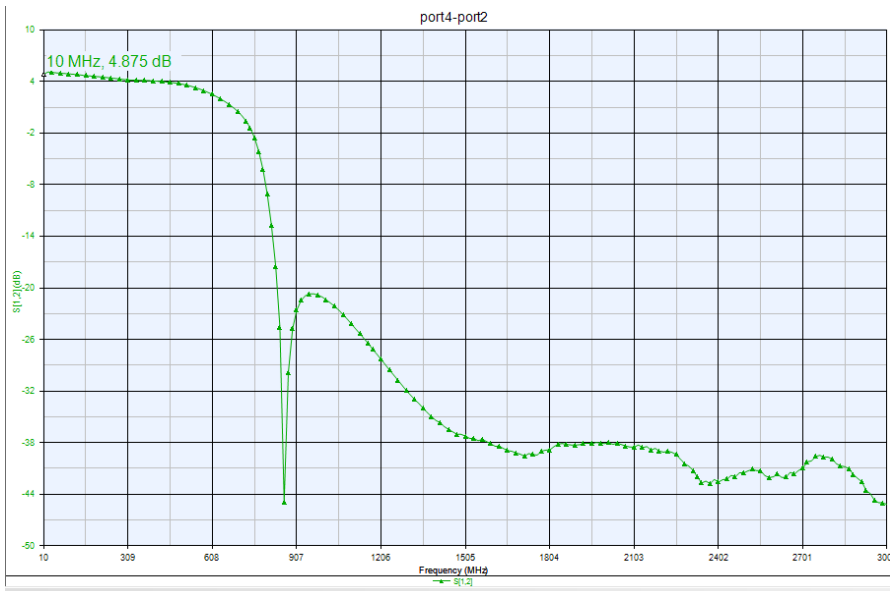

Insertion Gain
(0 dB Attenuation)

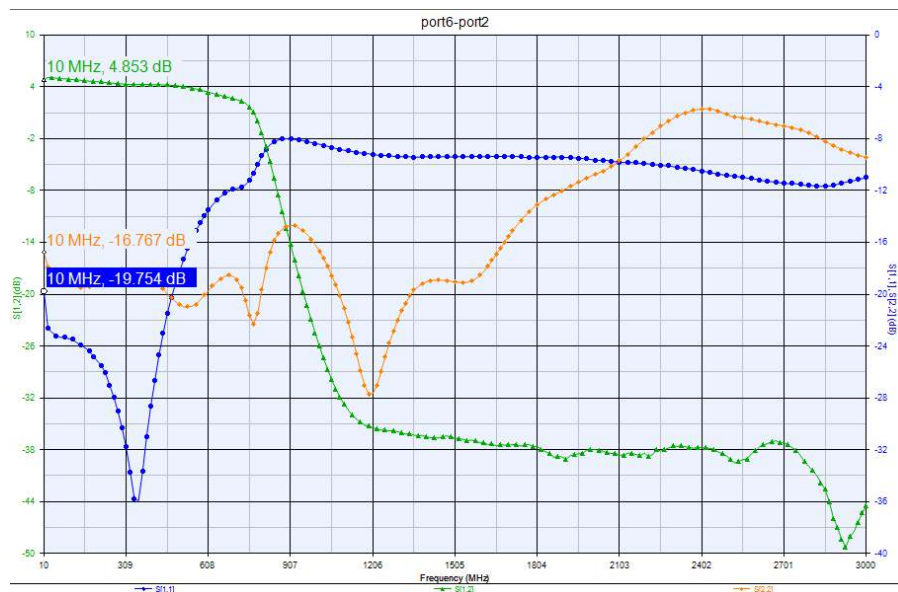

S2P (Return Loss –
Input & Output)

Orbital Research Ltd. designs and builds products for satellite communications applications. Orbital website: www.orbitalresearch.net. Copyright © 2017 Orbital Research Ltd. All rights reserved. Specifications subject to change without notice.