

# Split the signal from a Single Modem for Redundant BUCs

Orbital 2 way Divider - extracting 10 MHz from the Modem and using a 10 MHz switch to enable one of a pair of BUCs...

An Orbital MT-25 Mux Tee in reverse extracts the 10 MHz signal from a modem for a 10 MHz Switch. Orbital Mux Tees multiplex the L-Band and 10 MHz signals for a pair of redundant BUCs.

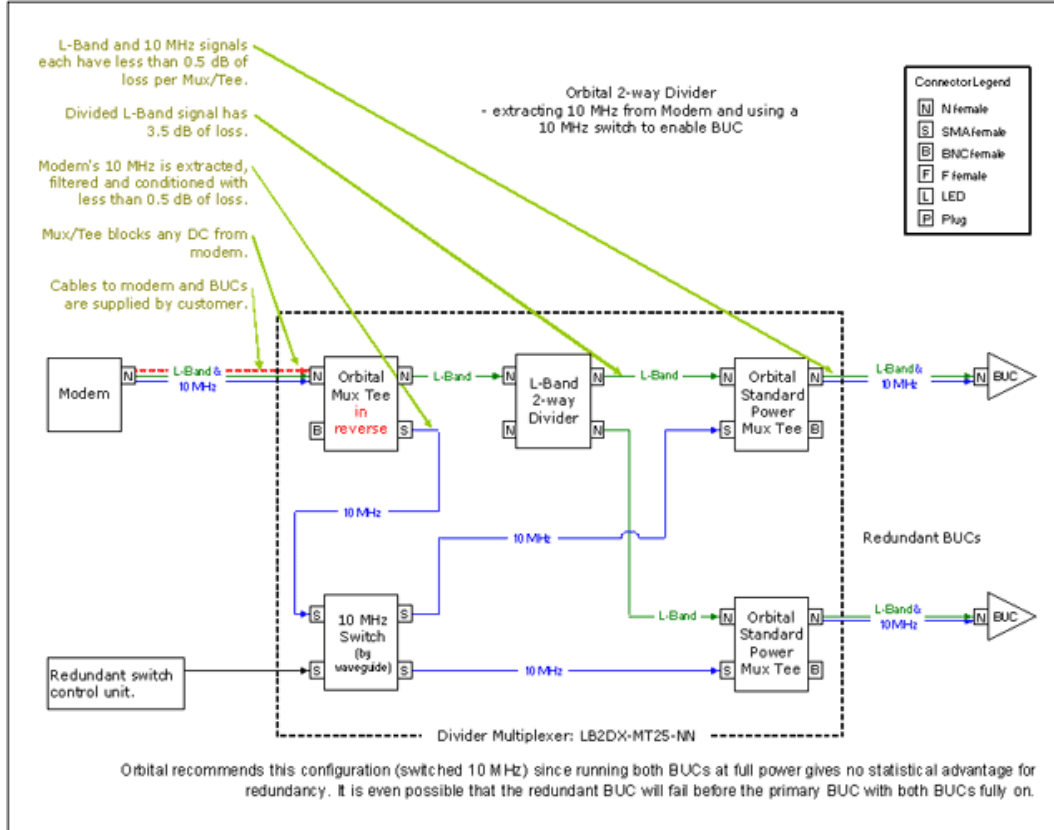

## Signal Line Legend

- DC Power
- L-Band
- 10 MHz Reference



MT25/40 - Bias Tee Multiplexer

