

Using an Oscillator and 10 MHz Switch for Redundant BUCs

Orbital 2 way Divider - using Master Oscillator and 10 MHz Switch for redundant BUCs...

L-Band signals from a single modem is divided to feed two Hi Power Mux Tees, while the Orbital Master Oscillator provides a source to a 10 MHz Switch. The 10 MHz switched signal is used to enable the BUC. A pair of Orbital MT-40s multiplex the 10 MHz with the L-Band and DC power for the selected BUC.

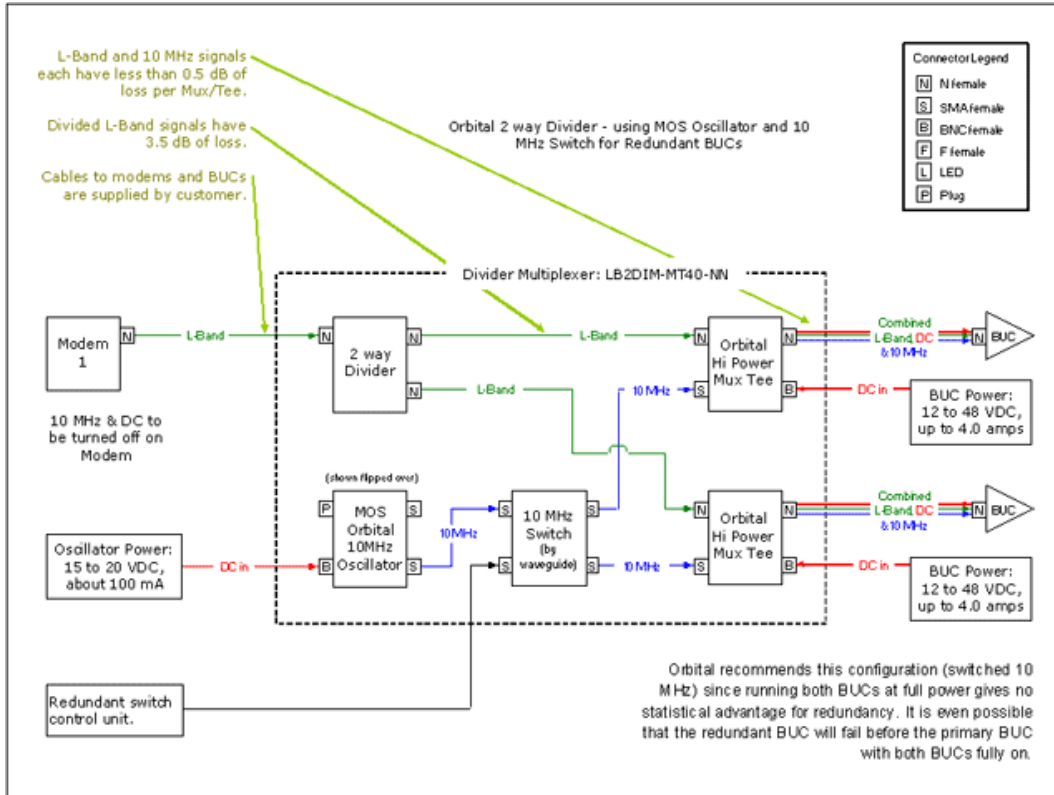

Signal Line Legend

- DC Power
- L-Band
- 10 MHz Reference



MOS -
10 MHz
Master
Oscillator

