

Have a single Modem feed a pair of BUCs

Orbital 2-Way Divider - extracting 10 MHz from Modem

A Mux/Tee in reverse is used to block the DC from the modem, but extract the L-Band and 10 MHz signals. The 10 MHz is sent to an Orbital 10 MHz Splitter to provide a reference signal to a pair of Hi Power Mux Tees. The L-Band signal is routed through a two-way L-Band Divider and then sent to the pair of Mux Tees. Each Hi Power Mux/Tee multiplexes the two signals with DC Power and feeds one of a pair of BUCs.

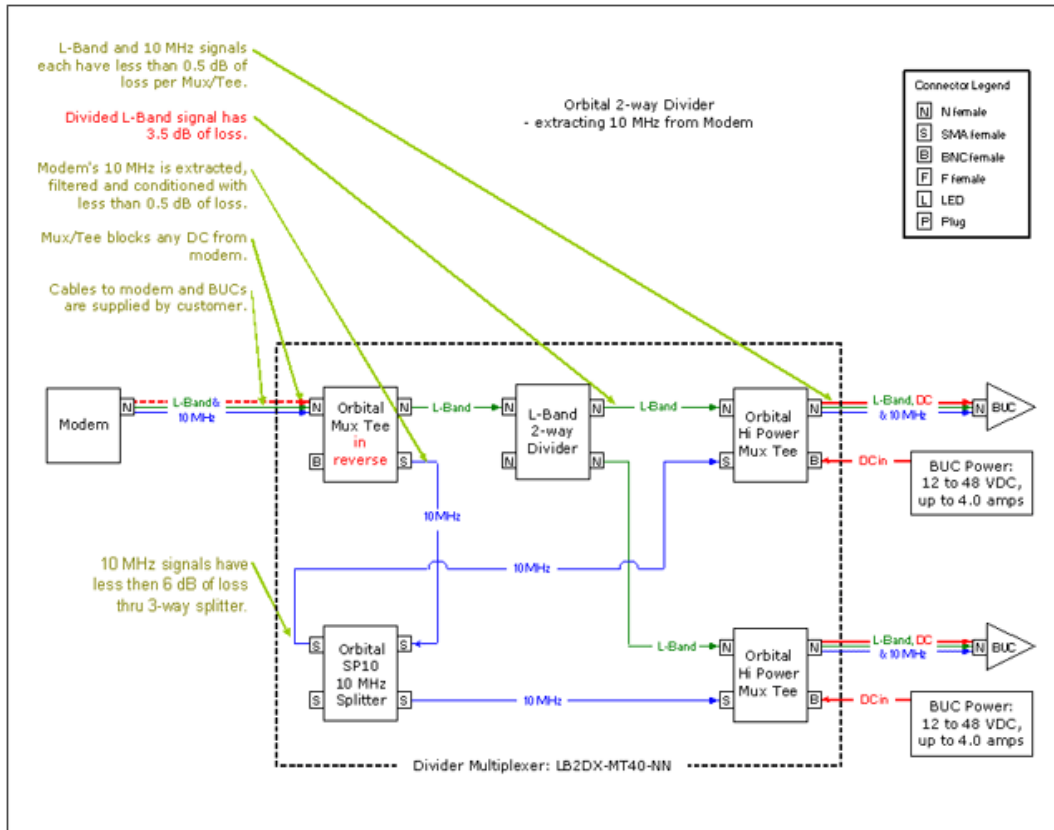

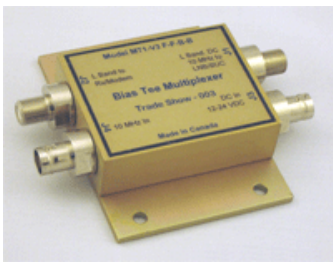

MT-40
Mux/Tee

