

## The BUC starts Here

### Using Orbital SIP products to Route Signals

Many of the world's largest satellite businesses use Orbital's Systems Interface Products to insert, extract, mux, filter, amplify, combine, divide, and switch their signals. We also build conversion systems that use our BDCs and LNBS in conjunction with Systems Interface Products to provide integrated down-conversion solutions.

Your unique problems require unique solutions for optimal results. Orbital's devices are modular in design, which means that you can build your solution from an array of matching components, such as oscillators, bias tees, diplexers, mux tees, dividers, combiners, splitters, TTL switches, BDCs, LNBS, etc. Below are a few examples that solve common routing problems. The examples are far from exhaustive.

Orbital's products are environmentally sealed, so they provide both indoor and outdoor solutions.

Most Orbital SIP standard Systems Interface Products, such as Mux Tees, Oscillators, 10 MHz Splitters, Bias Tees, Diplexers, etc., are in stock.

Some devices, such as Mux Tees, have more than one version to permit impedance transforms and a variety of connector choices.

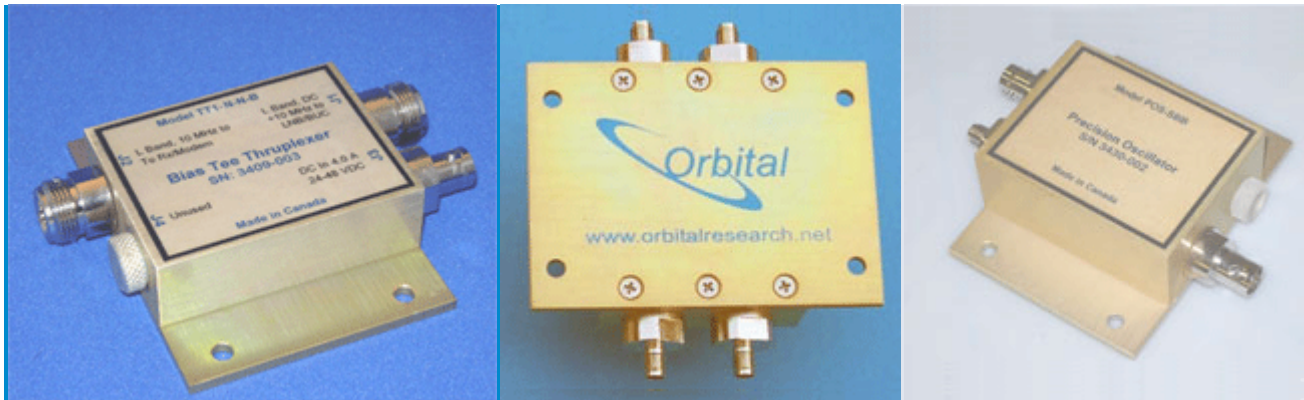

Below are a few solutions for common satellite signal routing problems:



Your problem might be as simple as a modem with insufficient power for your new BUC. The Orbital Hi Power Thru Tee will block the DC on the line from your modem, it will filter and condition your L-Band and 10 MHz signals with minimal loss, and it will allow you to insert up to 4 amps at up to 48 VDC.

#### Advantage:

You can use your existing modem - you don't have to buy a new one. This is a plug and play solution: minimal downtime, easy install, no removal and replacement and reprogramming of the modem. This is a low cost, fast solution that also has the potential for add-on redundant LNB, BUC, or BDC power with our redundant power module.

## Standard Application for an Orbital Hi Power Thru Tee

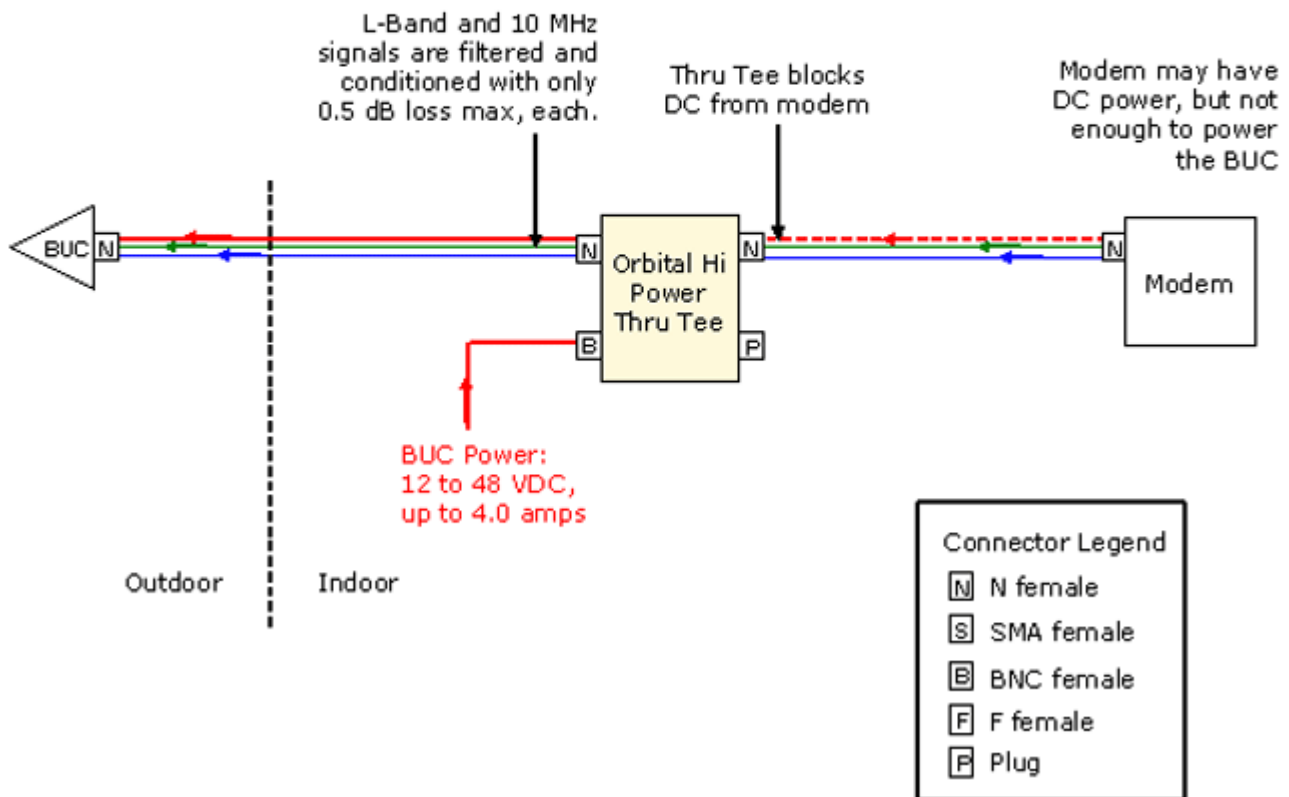

An emerging trend is the addition of a second, third, or fourth modem to the VSAT for additional end users, each having their own unique data and security requirements.

Here, the signals from four modems are combined and locked to a common 10 MHz reference, and high power DC is inserted to the BUC.

If a modem provides the 10 MHz source, an Orbital Mux Tee reversed from its normal orientation will extract the reference signal from a modem, allow it to be re-routed around the combiner, and then re-inserted into a second Orbital Hi Power Tee in its normal configuration.

It is imperative that the 10 MHz reference signal be handled separately from the power and L-Band signals to prevent signal loss, contamination from spurs, transients and harmonics from the power or modem, and the dreaded 'cycle slip' with external reference LNBS and BUCs.

### Advantage:

You can offer increased capacity for a new customer on an existing system with minimal upgrade costs or time delays.

**Orbital 4-way Combiner with 10 MHz Oscillator and hi power DC insert.**

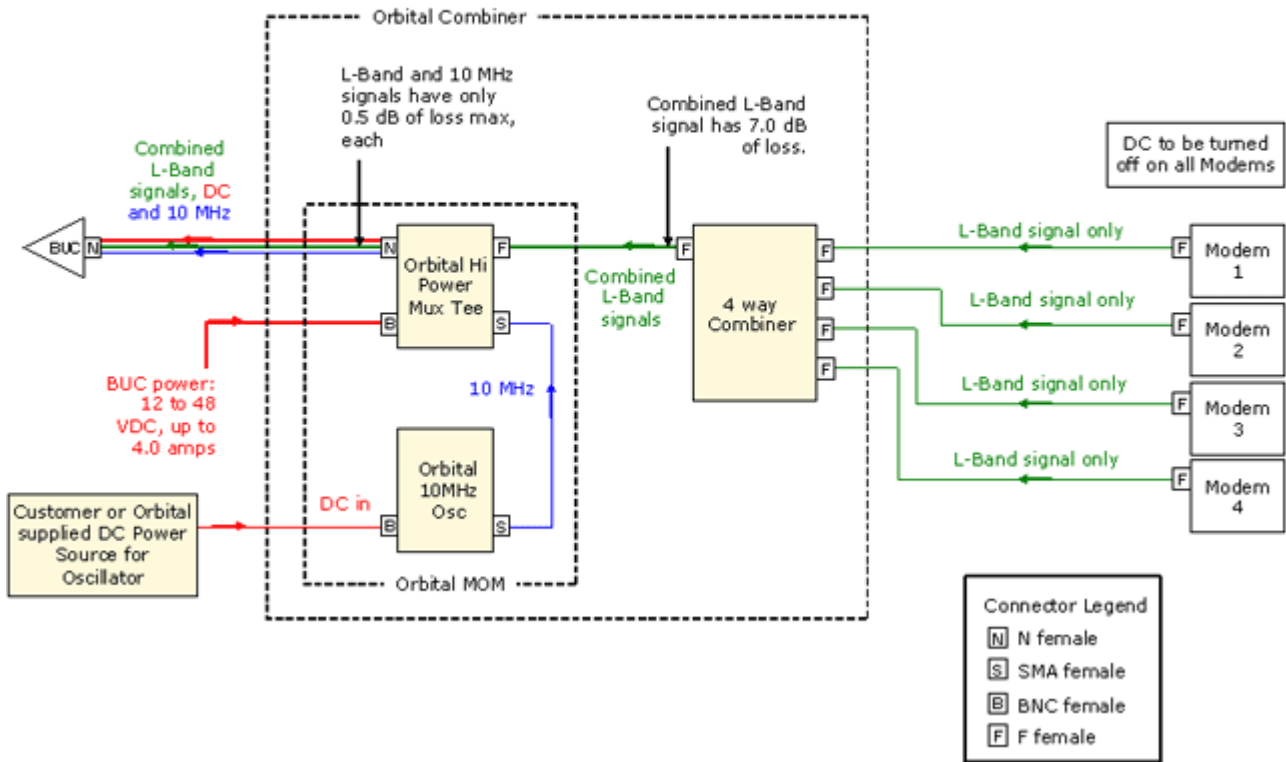

In this example, the 10 MHz signal is extracted from a single modem by an Orbital Mux Tee in reverse (an Orbital standalone 10 MHz Oscillator ( MOS or POS ) could be used in place of the modem oscillator ) The L-Band signals are passed through to the 2-way combiner, while the DC from the modem is blocked. When the L-Band signals from the two modems are combined, the 10 MHz reference is routed around the combiner re-integrated into the combined L-Band signal with an Orbital High Power Tee. At no extra cost, the client can insert the DC power to the BUC at this point, eliminating the need to have an extra cable out to the BUC, or to have power outside at the BUC.

**Advantage:**

You can offer increased capacity for a new customer on an existing system with minimal upgrade costs or time delays.

**Orbital 2-way Combiner using 10 MHz  
from one of the modems and Hi  
Power Mux/Tee to insert BUC power**

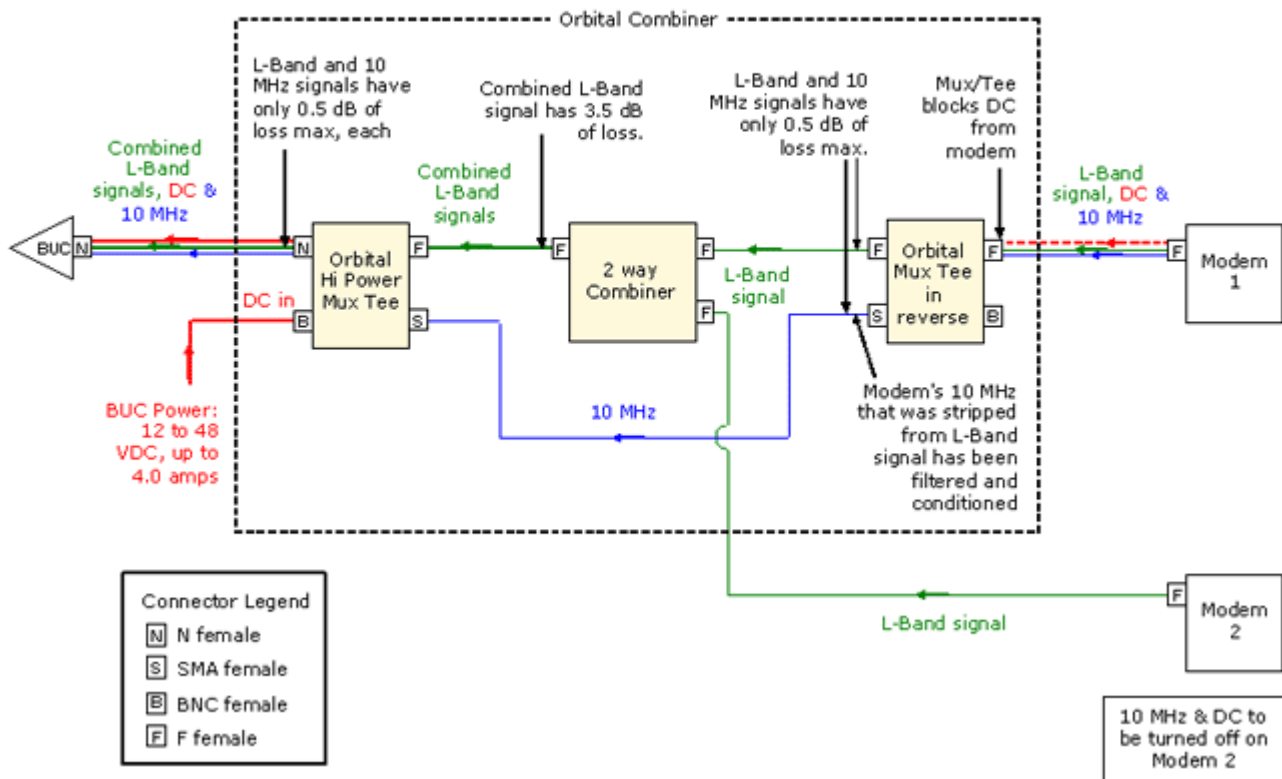

Redundancy is on the rise, and splitting power, L-Band and 10 MHz to feed dual BUCs - one live and one standby, is not a trivial issue. There is also a problem with redundancy when switching BUCs - the conventional waveguide switch uses SMA relay contacts on the output. You CANNOT put DC through these contacts. We use the existing BUC L-Band IFL cable, if it is of good quality and can handle the current, then extract it and split it to feed both BUCs. The L-Band signal and 10 MHz go through the SMA relay without the problem of DC on an RF switch.

Here is how to do it right.

In this case, the L-Band output of a pair of modems is combined with the 10 MHz signal from an Orbital Master Oscillator. Again, high power DC to the BUCs is inserted with a pair of Orbital Hi Power Tees. Divide and conquer...

**Advantage:**

Plug and play solution, no additional trenching, IFL or DC cables, no civils costs, rapid and easy deployment.

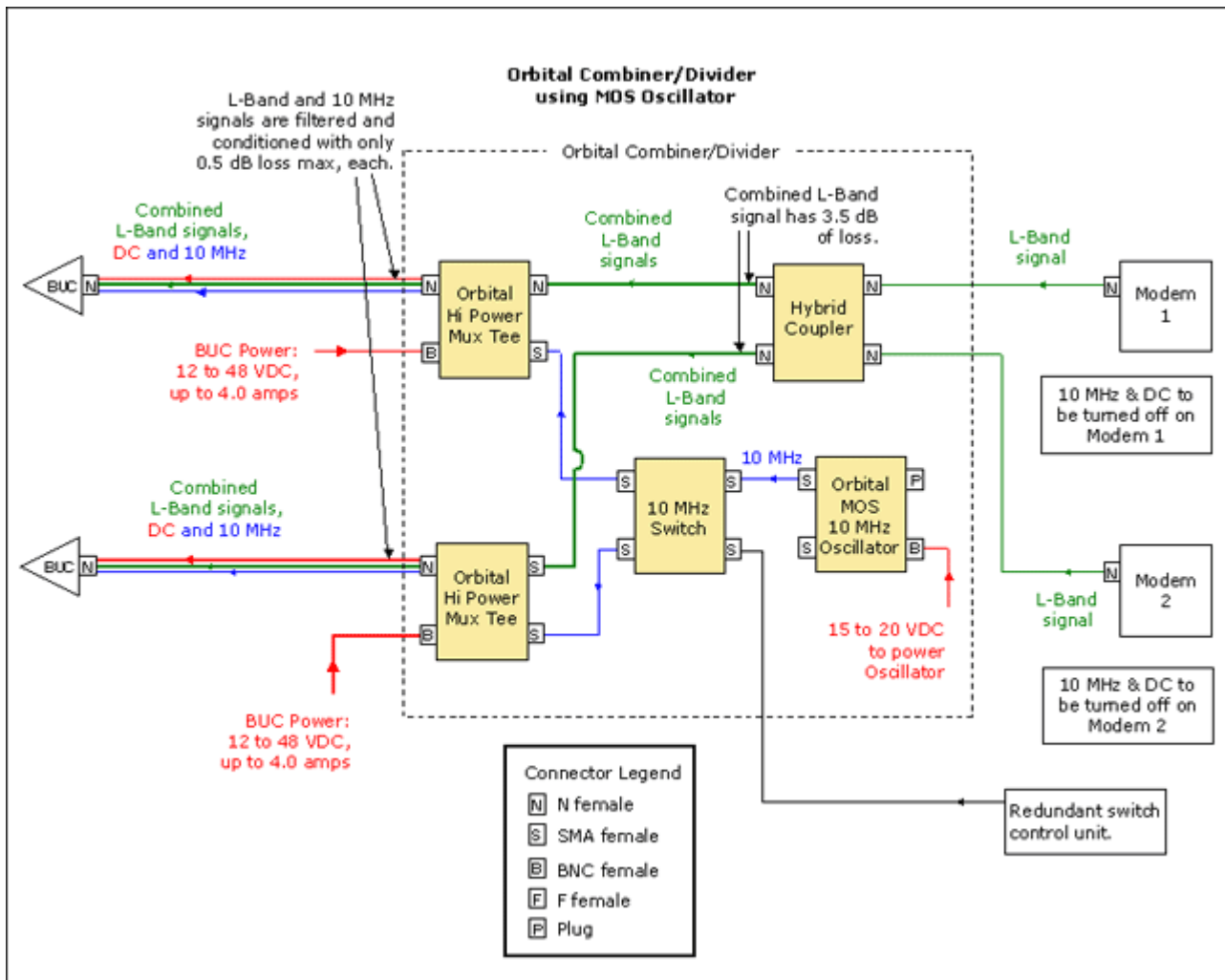

Here is another variant of 'doing it right'.

In this case, the 10 MHz source is provided by one of a pair of modems. This is also a redundancy situation, and the splitting of power, L-Band and 10MHz to the dual BUCs is paramount in maintaining the integrity of the signals. Again, there is the problem with redundancy when switching BUCs - the conventional waveguide switch uses SMA relay contacts on the output. Since you CANNOT put DC through these contacts, we use the existing BUC L-Band IFL cable, if it is of good quality and can handle the current, then extract it and split it to feed both BUCs. The L-Band signal and 10 MHz go through the SMA relay without the problem of DC on an RF switch.

Here, rather than an independent oscillator, we use the 10 MHz output of one of the modems to provide the reference signal. The combined L-Band signals from both modems are split to feed both BUCs. The Orbital Mux Tee in reverse strips the 10 MHz and routes it around the hybrid coupler and through the 10 MHz splitter - two thirds of the work is done. These are new high power BUCs and we have to provide high power DC, so a pair of Orbital Hi Power Mux Tees will mux together the L-Band, 10 MHz and DC power - all cleaned and filtered with minimum loss.

## Advantage:

Plug and play solution, no additional trenching, IFL or DC cables, no civils costs, rapid and easy deployment.

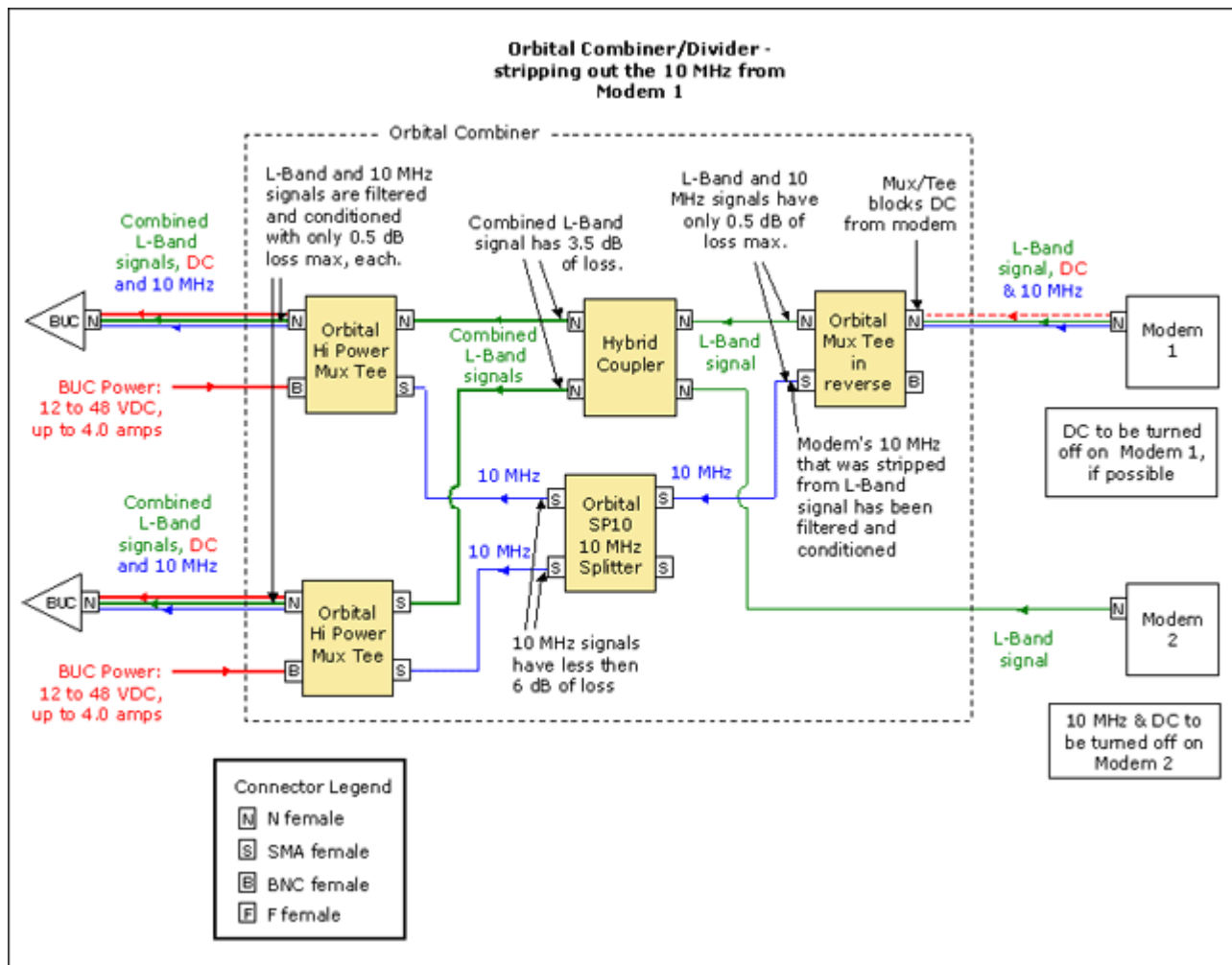

It is possible that you have a modem with insufficient DC power to power a BUC ( or BUCs ).

Here, you can use an Orbital Hi Power Thru Tee to block the DC from the modem, insert up to 4 amps at up to 48 VDC inside, use a High Power Thru Tee in reverse, outside, to pass the 10 MHz and L-Band signals, while the DC is routed through a power divider.

In the case of a switch being used for the L-Band and 10 MHz signals, power is still provided to each BUC through the power divider, but only the BUC receiving the 10 MHz reference will be active.

## Advantage:

Plug and play solution, no additional trenching, IFL or DC cables, no civils costs, rapid and easy deployment.



**Using an Orbital Hi Power Thru Tee to circumvent a Divider or switch**

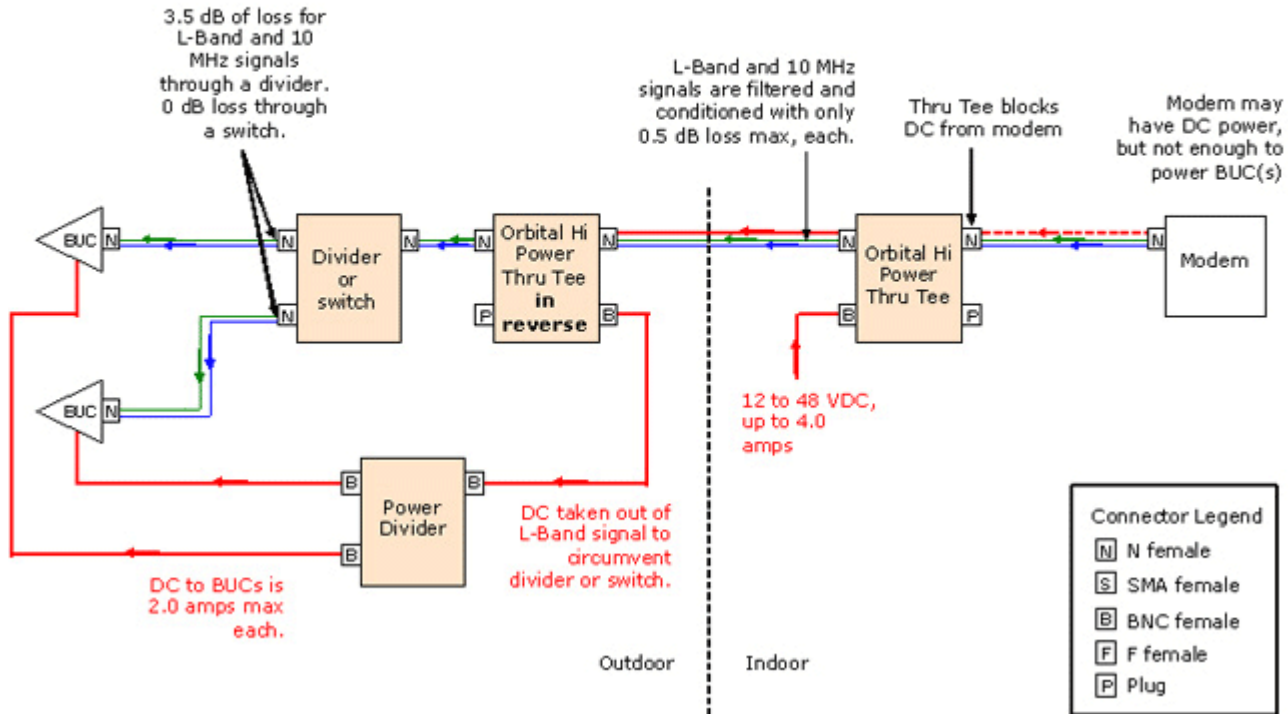

... Or you may have a really exotic problem. Either way, our engineers will help you solve it.

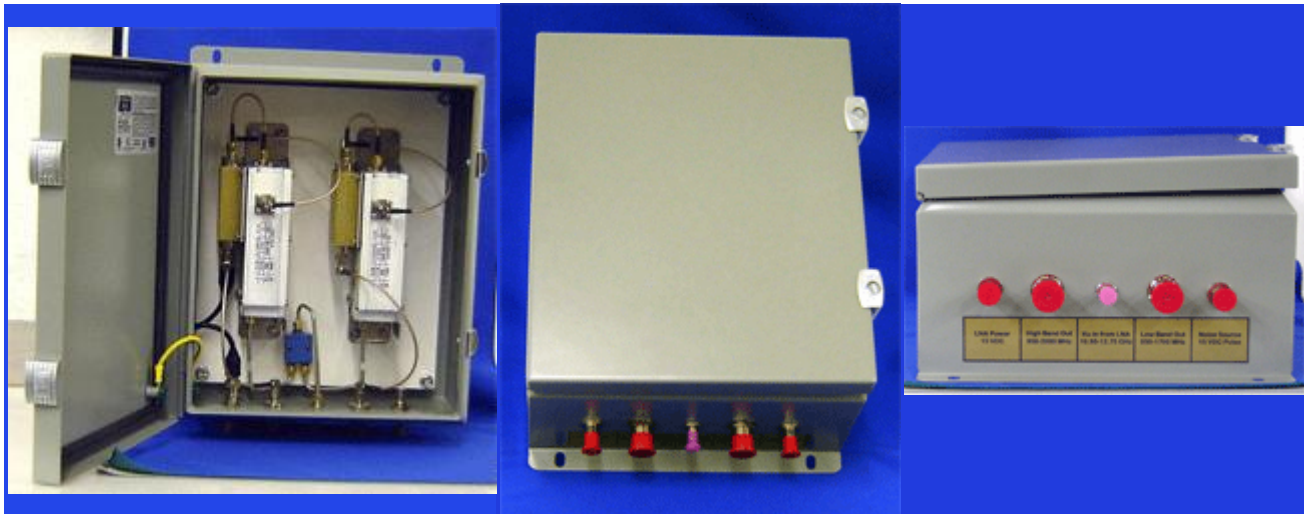

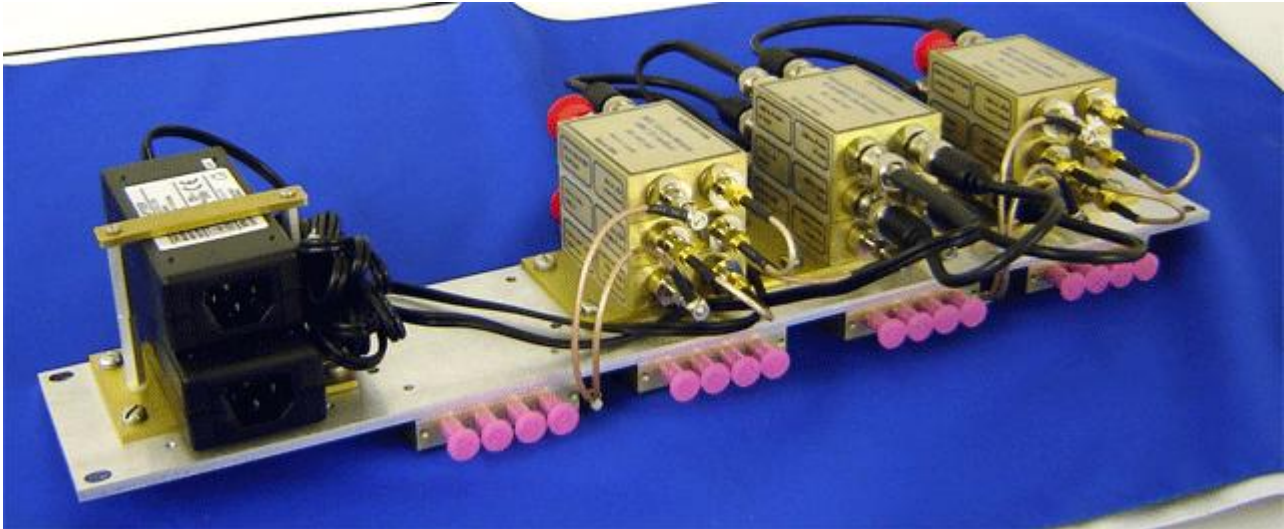

**Contact Orbital Research at:**

**Tel: 604-856-0305**

**Fax: 604-856-0315**

**email: [davidzuvic@orbitalresearch.net](mailto:davidzuvic@orbitalresearch.net)**

**website: [www.orbitalresearch.net](http://www.orbitalresearch.net)**