

U-Tube (X Band Compact Reception System) Test Data:

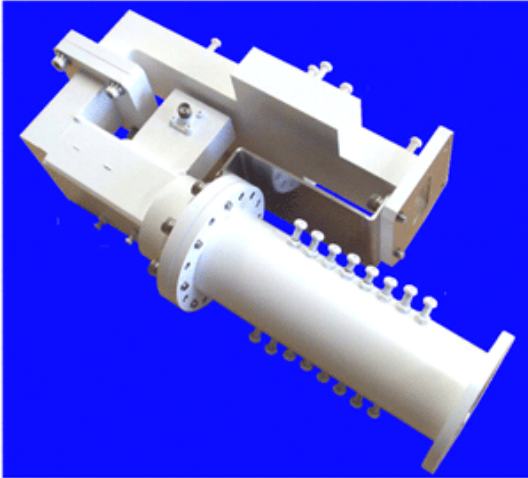

It is clear that the U tube assembly with the LNB is superior in all measures to comparable conventional assemblies, but how good is the U tube fixture without its custom integrated LNB?

The following graphs show the performance of the Polarizer, the OMT and the Receive Bandpass Filter, just in case you want to bolt on your own X band LNB. Notice the low insertion loss, the excellent return loss, and the isolation, even without a Tx Filter.

These plots were taken from actual pre-production samples that are now under evaluation by our clients, using of course, our High-Performance X Band LNB (with built-in 45 dB of Tx Reject).

NOTE: These results are for the receive portion of the system only, which occupies a volume of just 5 by 3 by 12 inches and weighs just 1350 grams with the LNB included. It does not include the use of our excellent Transmit Bandpass Filter which adds an incredible 92 dB of Transmit to Receive isolation and just 380 grams in weight and 1 inch in width when added to the system.

No.	Items	Specifications (Target Spec)	Test Data	
			U-Tube1	U-Tube2
1	Pass Band	Rx: 7.25~7.75GHz Tx: 7.9~8.4GHz	Same as Spec	Same as Spec
2	VSWR	Rx: 1.3 max Tx: 1.3 max	Rx: 1.12 Tx: 1.10	Rx: 1.22 Tx: 1.11
3	Tx Attenuation	35dB min at 7.9~8.4GHz	35.8dB	35.7dB
4	Tx/Rx Isolation	40dB (target) at 7.25~8.4GHz	39.6dB	38.5dB

U-Tube 1 - Without LNB

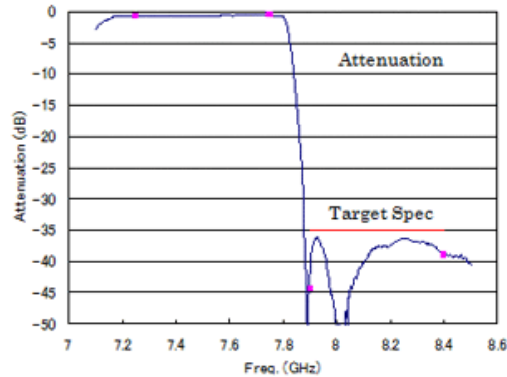
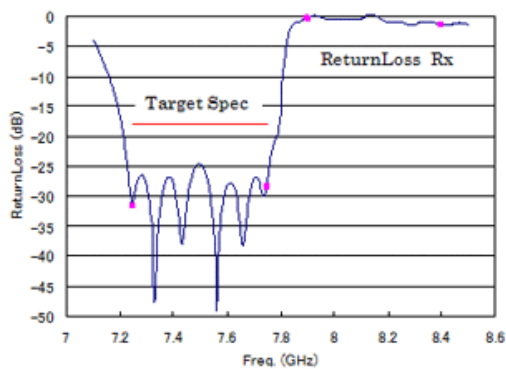

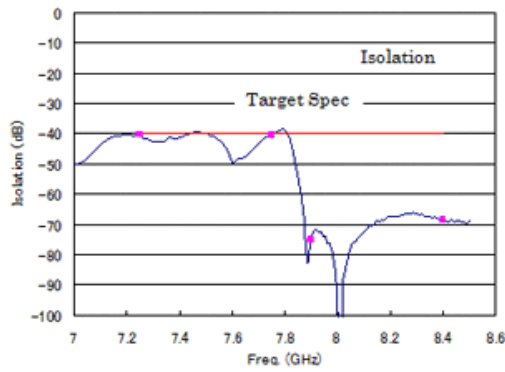
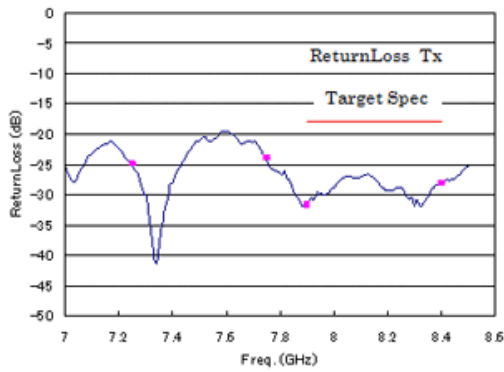

U-Tube 2 - Without LNB

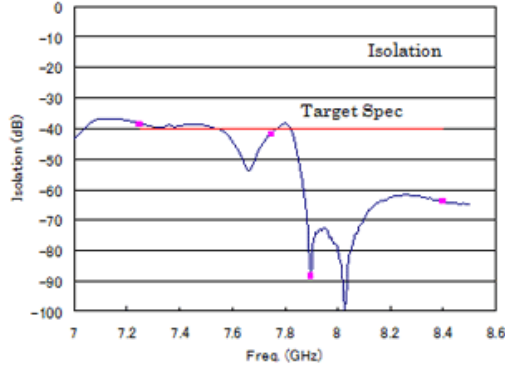
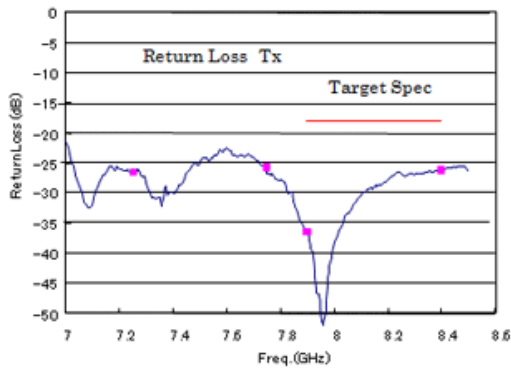
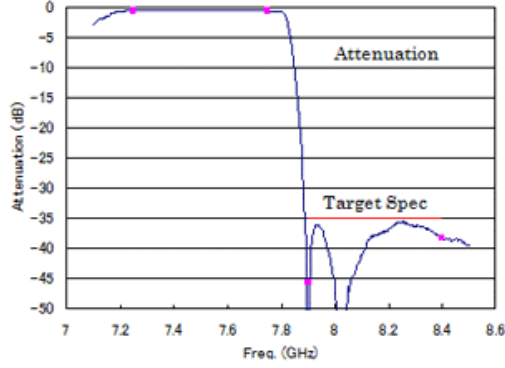
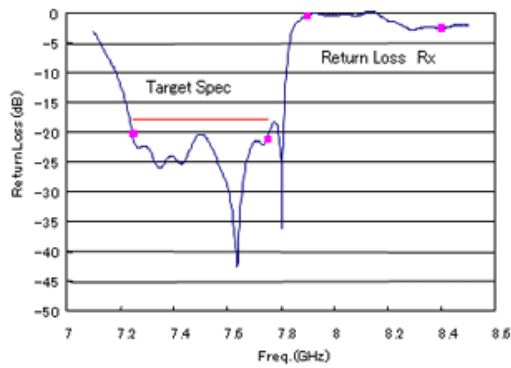

U-Tube X Band with the Orbital LNB

While the U Tube components work well with any LNB, the addition of the Orbital LNB that has been specifically engineered to optimize all parameters as a system provides the maximum benefit for the system designer. Paying careful attention to VSWR matching, minimization of insertion loss, and band flatness and ripple management, the U Tube assembly provides maximum gain, minimum noise and optimal rejection of transmit artifacts. And it does all this while dramatically reducing the overall size of the combined elements, minimizing weight, balancing center of gravity for feed mounting management, reducing loading on feed struts, minimizing occlusion by feed components, preserving environmental

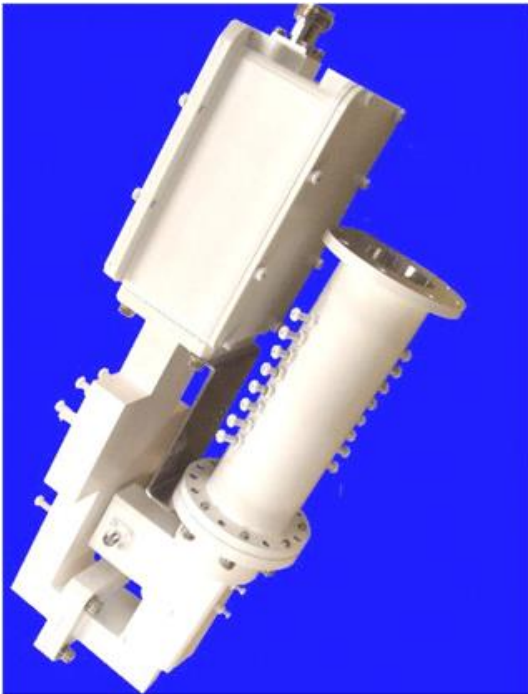

integrity, and reducing the impact of vibration on both system electrical performance and mechanical integrity. The compact design and greatly reduced weight also benefits the setup, teardown and storage considerations of system deployment and transportation.

Performances of U-Tube 1 & 2 with LNB

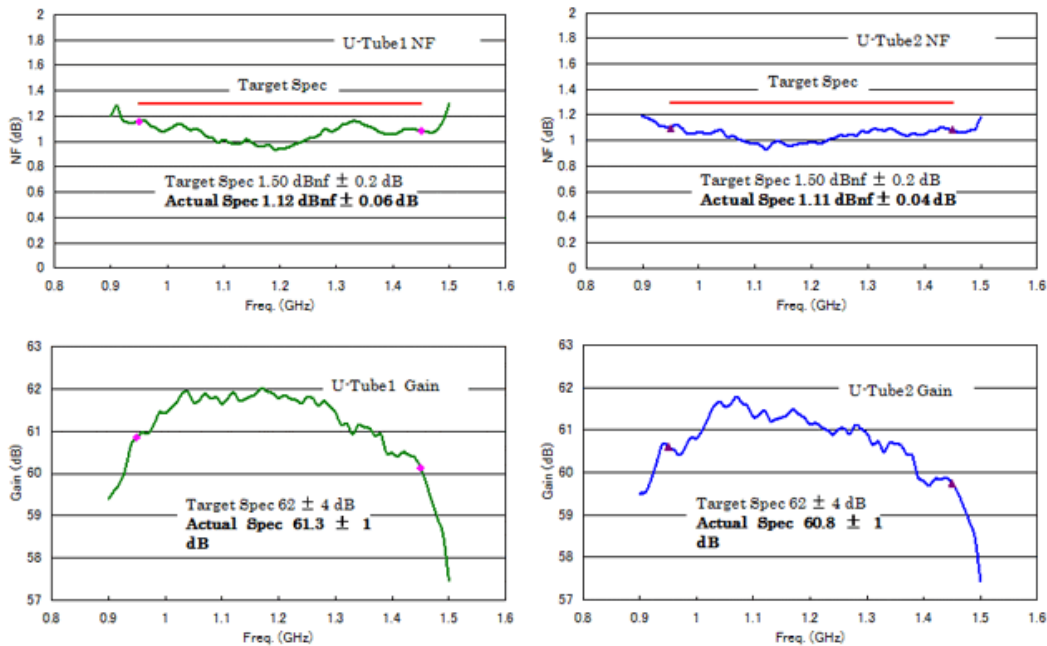

Compare U-Tube 1 & 2 With and Without Isolator

Isolators are used in microwave to establish impedance matching to minimize the destructive effects of reflected energy upon the incoming signal as it passes through each component. Isolators are very effective in this role, but the price paid for reduced VSWR is Insertion Loss. Any insertion loss is effectively added to the noise figure of the active device, in this case, the LNB. Therefore, the saving in losses from destructive signal cancellation from reflected standing waves, VSWR, must be greater than the insertion loss of signal in going through

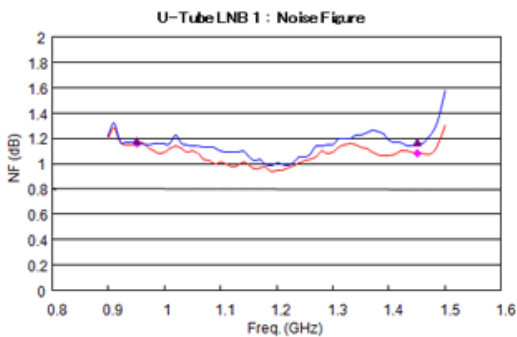
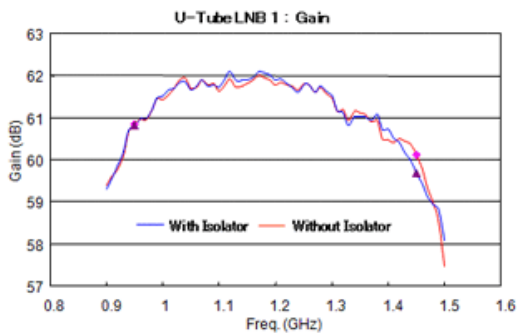

the isolator.

However, the signal levels are so small in today's mobile satellite terminals, and the noise figure so low in today's sophisticated LNBs that insertion losses as low as 0.1 or 0.2 dB are very significant additions to noise figures of 0.5 to 0.7 dB. Therefore, it is very desirable to design an integrated system where each component is carefully matched to each other in the signal chain to minimize VSWR and insertion loss and eliminate the need for the isolator. Not only can you improve noise figure, but you eliminate the size, weight, and cost of the isolator. When you are buying parts from different vendors, you have no control of the match or any ability to optimize VSWR or insertion loss. With the U tube system, this optimization has been done for you, and the savings in weight, size, cost and noise figure are now yours.

The difference in noise figure between a standalone LNB, and the U tube system with an added Polarizer, OMT, and Receive Bandpass filter in front of the LNB is only 0.4 dB. This is less than the insertion loss of some filters alone. A La Carte construction cannot compete with engineered efficiency.

Testing Fixture for Noise Figure and Gain

The measurements in the preceding slides were made with this test jig. It is important to provide clarity and confidence in the measurements that represent the performance of the components in your system. If you require information on the protocols and principles involved, or a list of the test equipment and noise figure analyzers used in the tests, please ask.

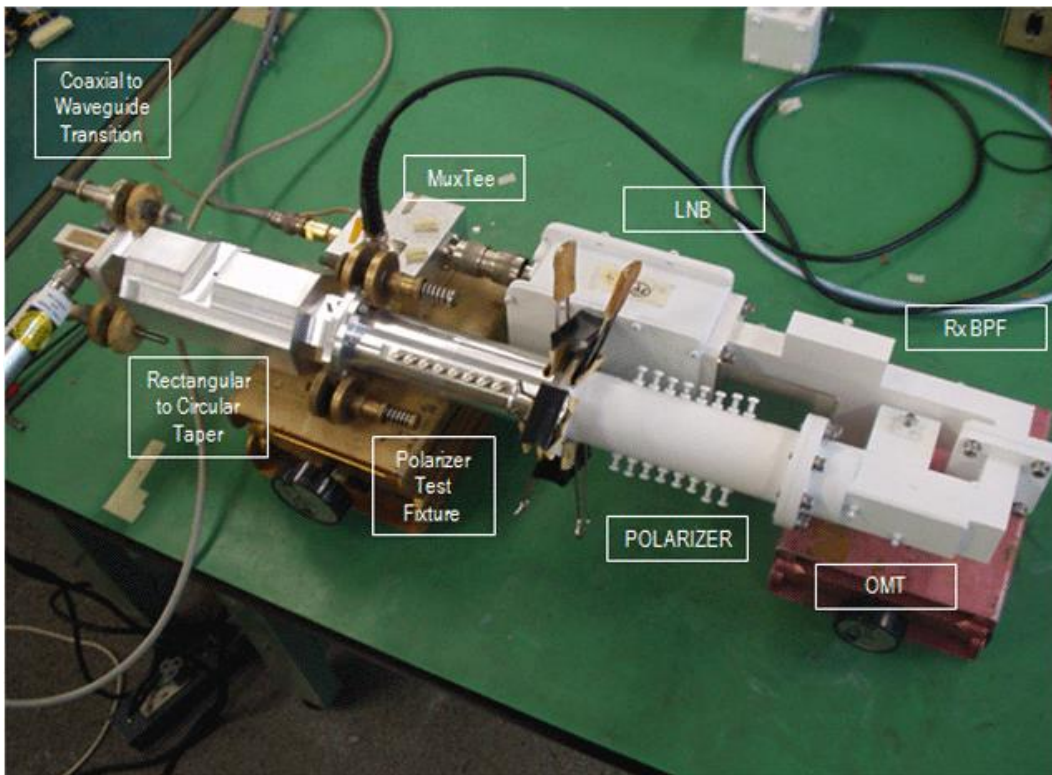

This block diagram represents the reflection coefficients encountered in the signal path from the antenna to the LNB output. Please note the equivalent input impedance of free air at 377 ohms and the terminal impedance of 50 ohms at the coaxial output of the system. The sum total of the long line effect of this impedance transformation without using an isolator for matching is less than 0.39 dB. This is the effective ripple of the system.

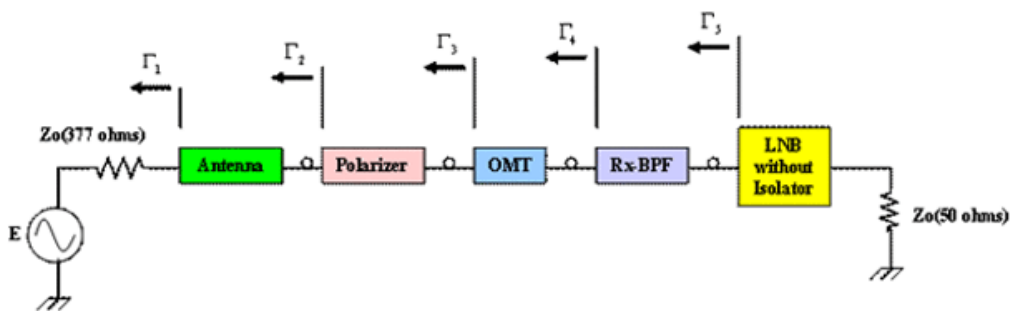

Fig-2. Long Line Effect due to cascaded connection components