

Use a Hybrid Coupler to Combine 2 Modems to feed 2 BUCs

Using an Orbital Hybrid Coupler to combine the signals from two modems and divide them to feed two BUCs - using 10 MHz from one of the modems.

The L-Band signal from both of the modems goes to the Hybrid Coupler where it is combined and split to a pair of High Power Mux/Tees. The 10 MHz reference is extracted and feeds a 10 MHz Splitter which redirects the signal to the pair of Mux/Tees. The Mux/Tees multiplex the DC power with the L-Band and 10 MHz to re-integrate the combined signal for each of the BUCs.

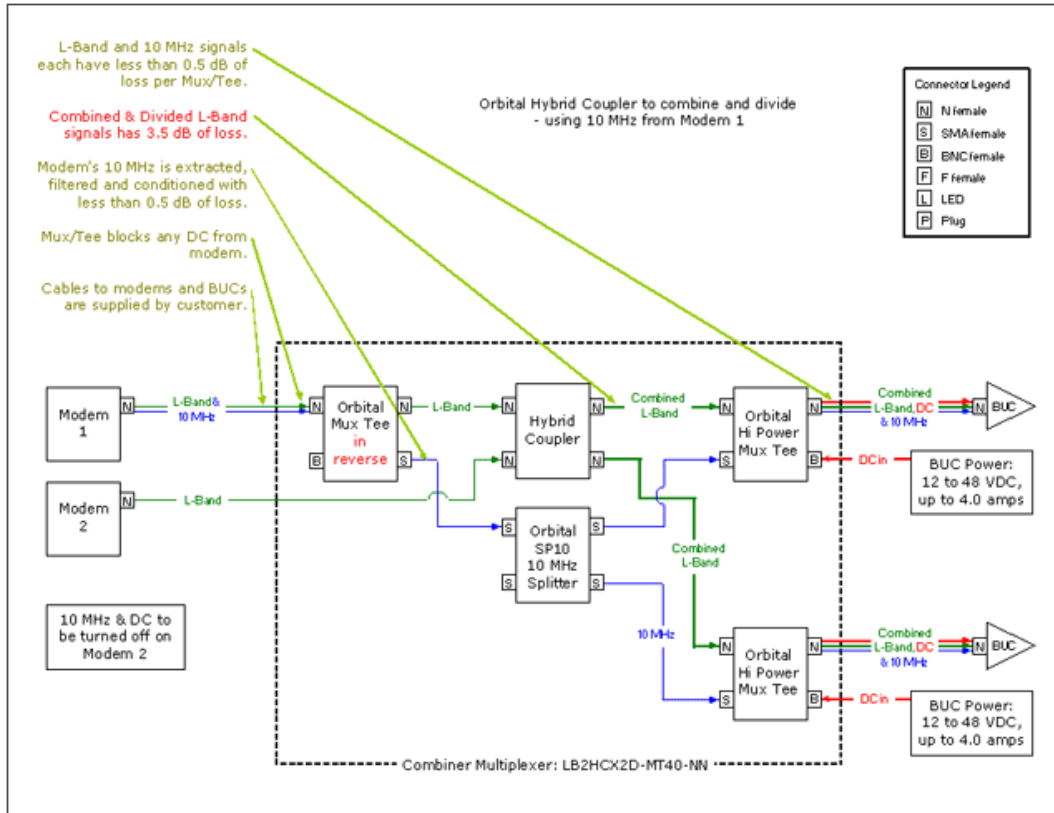

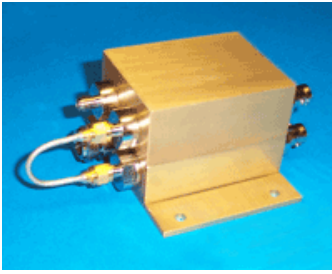

MOM - Master Oscillator Module

Shown as a stack, also available on a plate, or in a rack.

